

magg

welcome to



our world





mogg Scheda tecnica
Data sheet

PIANTA | PLAN
FRONTE | FRONT

METRICA A Libreria | Bookcase















Designer: Ctrizak
Anno | Year: 2017
Materiali | Materials: Struttura in metallo verniciato con ripiani in vetro | Painted metal structure with glass shelves

MGGG srl via A. de Gasperi 76 20833 | Gussano (MB) | Italy | t. +39 0362 1723880 | f. +39 0362 1585432 | www.mogg.it | info@mogg.it MADE IN ITALY

Inquadra il qr code con il tuo smartphone per vedere la scheda tecnica del prodotto.

Use your smartphone to scan the qr code and see the product sheet.

novità /
news

						
	and p. 4	dune p. 12	fractal credenza p. 20	fractal tv p. 24	era p. 28	
						
medusa p. 36	brera p. 44	la dori p. 50	nora p. 58	orbit p. 66	shape p. 74	uccio p. 80
						
flirt p. 86	metrica white p. 92	metrica tv p. 96				

and
design Fabio Bortolani & Stefano Maggi



Cassettiera con vani a giorno in mdf.
Finiture: laccato goffrato o lucido
in tutti i colori come da campionario.

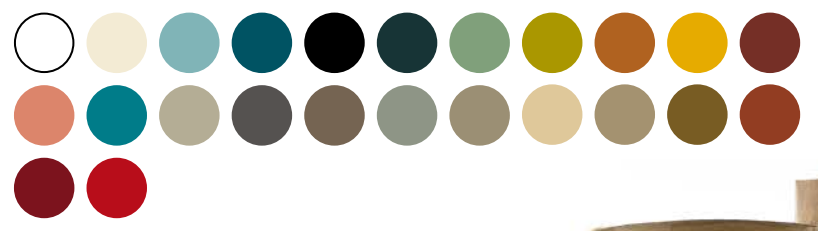

*Chest of drawers with open
compartments in mdf.
Finishes: matt goffered or glossy
lacquered as colors card.*

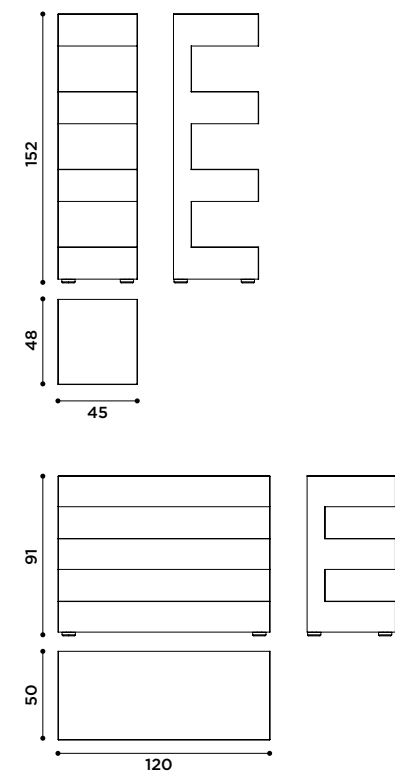







dune
design Simone Fanciullacci

2024



Tavolino in gres.
Disponibile nei colori: avorio,
antracite, terracotta.

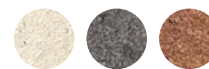

Stoneware coffee table.
Available in colours: ivory,
anthracite, terracotta.

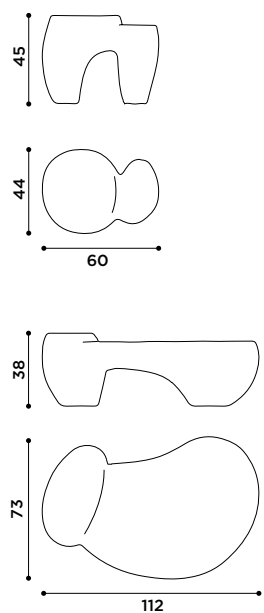





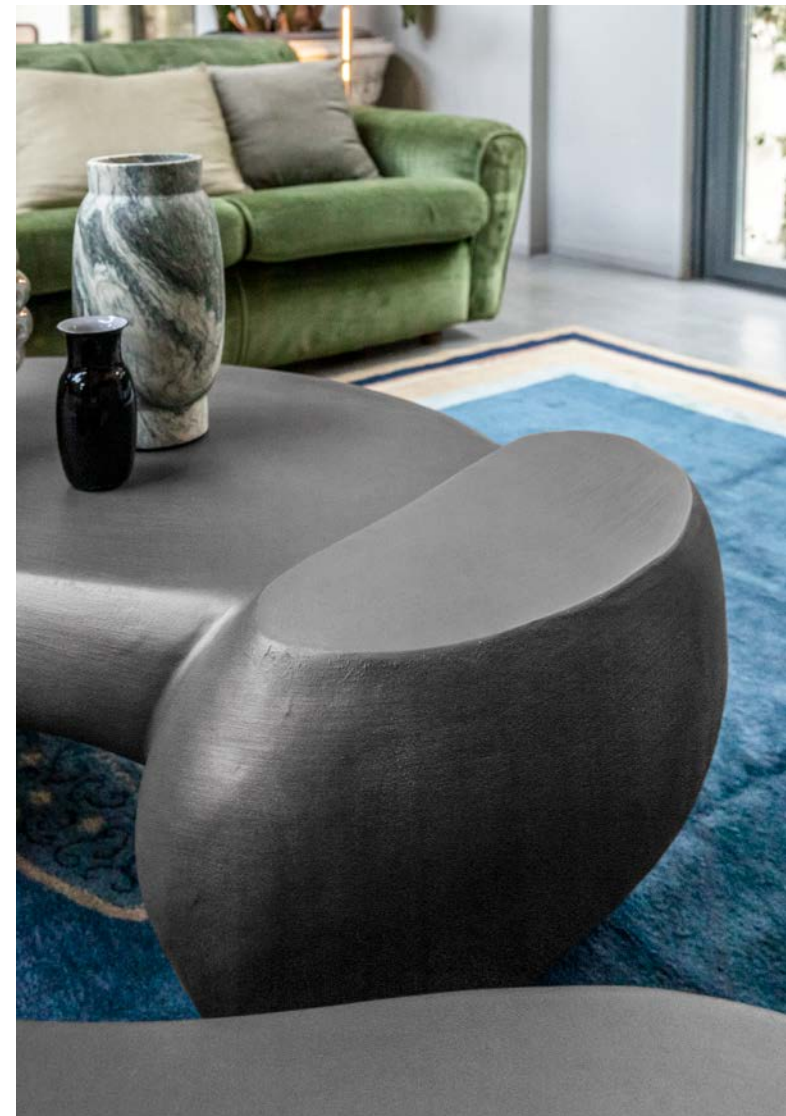

fractal credenza

design Bellavista Piccini



Credenza in mdf.
Finiture: laccato goffrato o lucido in tutti i colori come da campionario o frassino tinto MOKA.

Sideboard in mdf.
Finitures: matt goffered or glossy lacquered as colors card or MOKA stained ash wood.

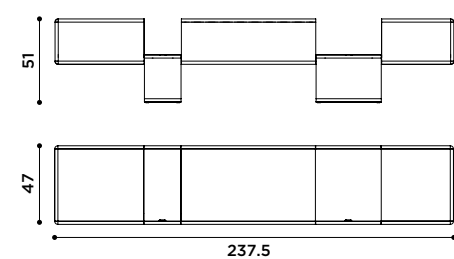
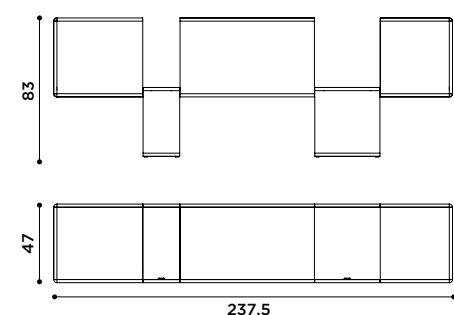
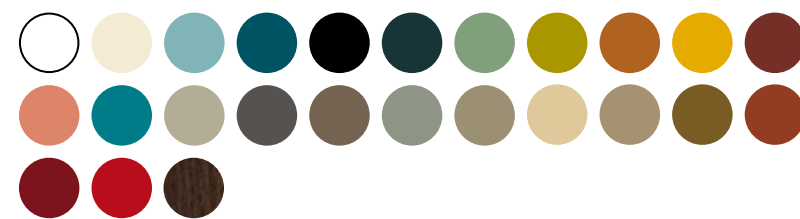



fractal tv

design Bellavista Piccini

2024

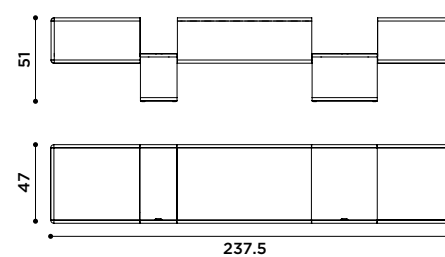
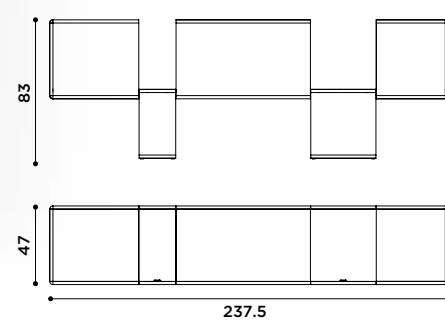

Mobile TV in mdf.
Finiture: laccato goffrato o lucido in tutti i colori come da campionario o frassino tinto MOKA.

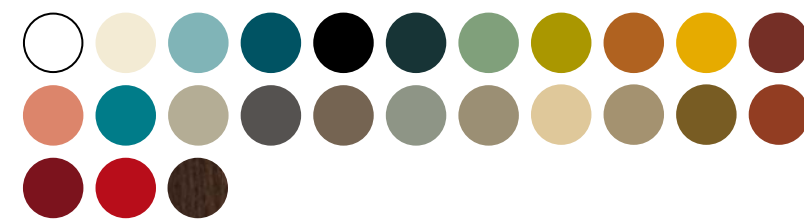

TV cabinet in mdf.
Finitures: matt goffered or glossy lacquered as colors card or MOKA stained ash wood.







2024



Lampada da tavolo in metallo.
Disponibile nei colori: bianco
RAL1013, nero RAL9017 o oro
satinato.



*Table lamp in metal.
Available in colours: white RAL1013,
black RAL9017 or satinated gold.*

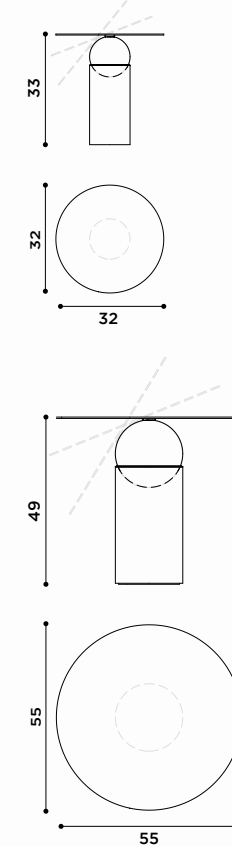



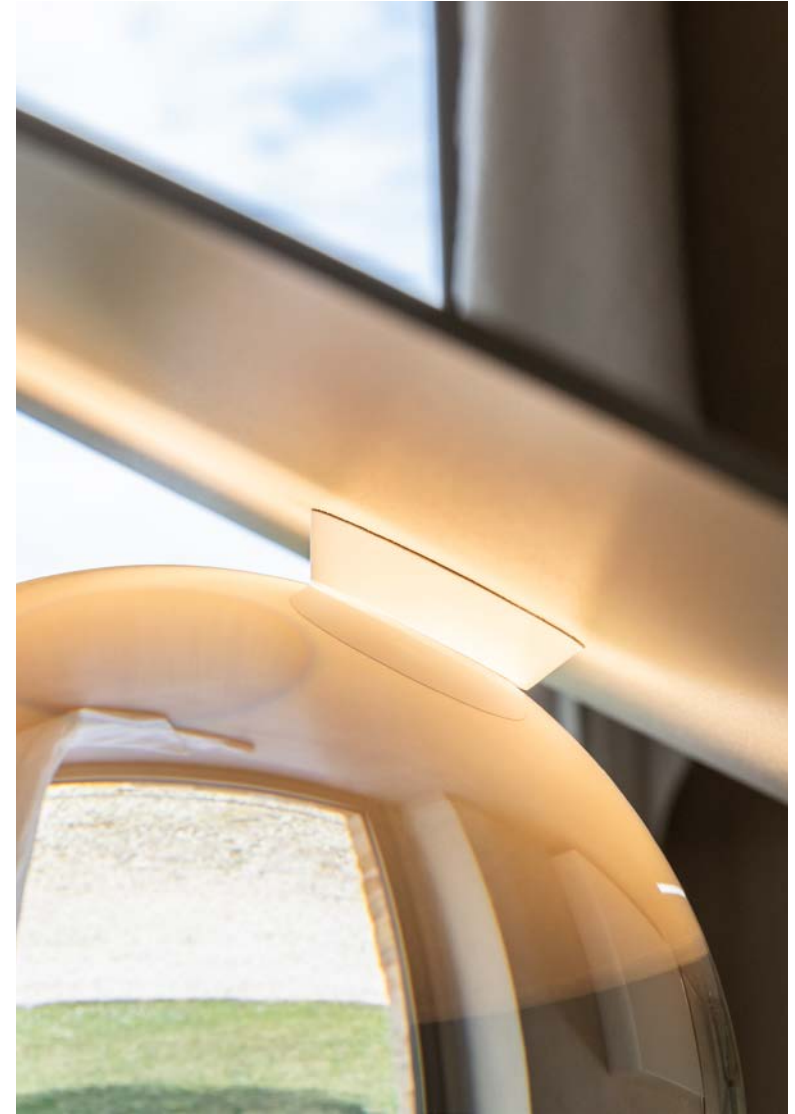





Tavolo con piano in legno e base in metallo.
Finiture: laccato opaco o lucido in tutti i colori come da campionario o materico spatolato a mano nei colori: bianco, nero, grigio, avorio e terracotta.

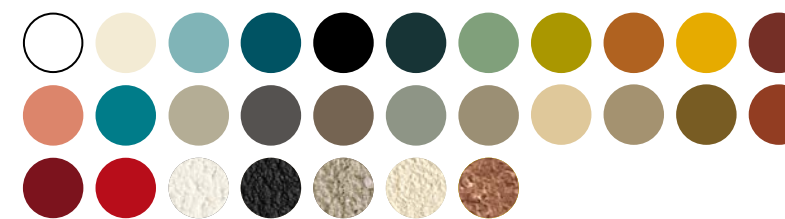
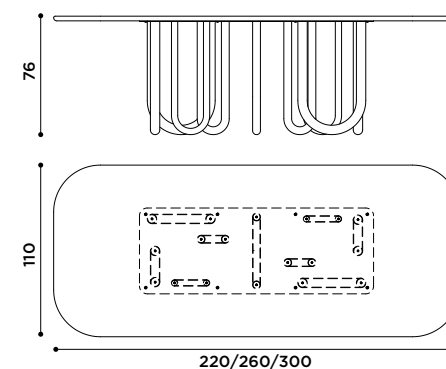
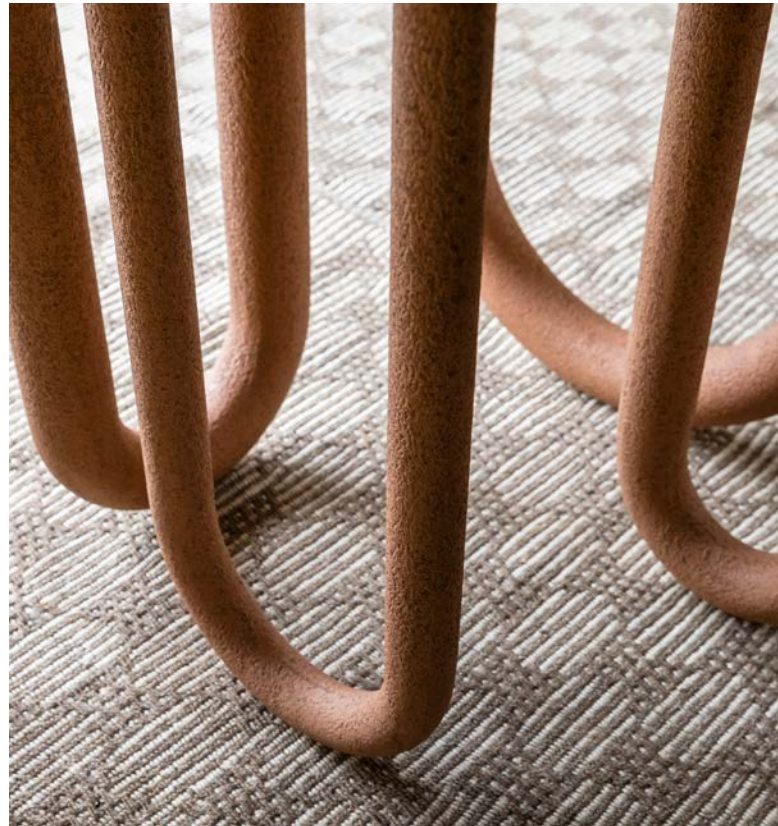

Table with wooden top and metal base.

Finishes: matt or glossy lacquered as colors card or covered with hand-spread materic finish in the colours: white, black, grey, ivory and terracotta.











Sedia imbottita.
Struttura imbottita con rivestimento
nei tessuti come da campionario.

*Upholstered chair.
Padded structure with cover in
fabrics
as per sample card.*

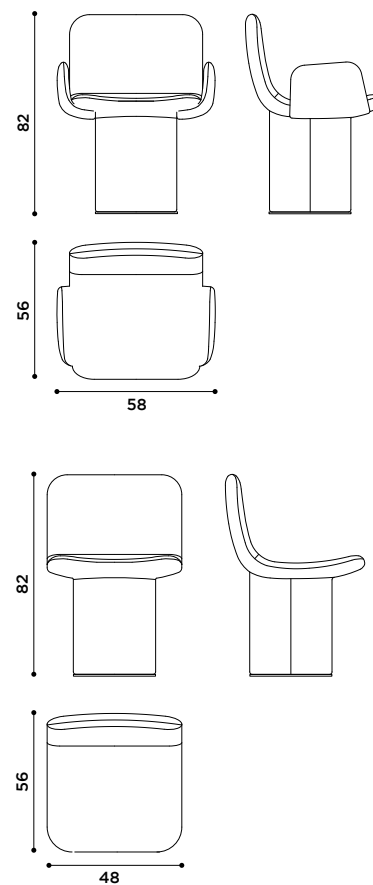





la dori
design Marco Pisati

2024



Colonna contenitore in multistrato curvato.
Finiture: laccato goffrato o lucido in tutti i colori come da campionario.

*Curved multilayer cabinet.
Finishes: matt goffered or glossy lacquered as colors card.*

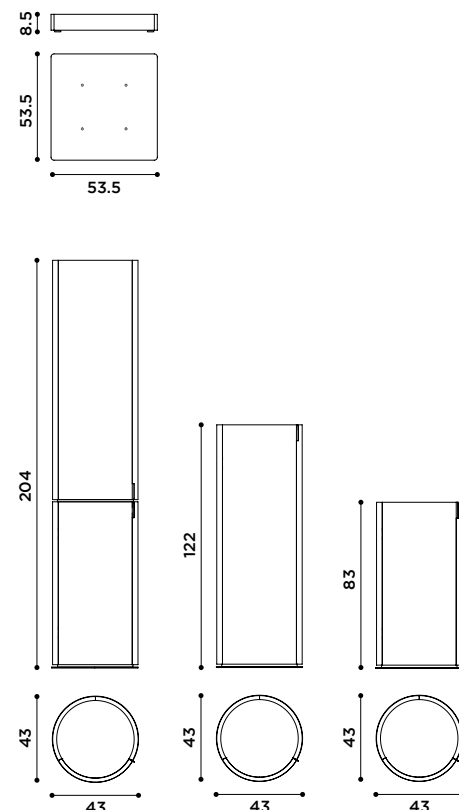







nora
design Alberto Ghirardello

2024



Poltroncina imbottita.
Struttura imbottita con rivestimento
nei tessuti come da campionario.

*Upholstered armchair.
Padded structure with cover in
fabrics as per sample card.*

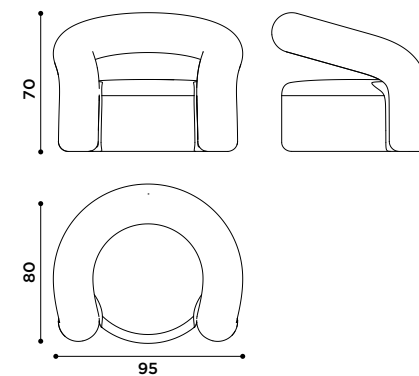









Lampada terra soffitto.
Sfera scorrevole sui cavi d'acciaio.
Base a terra e supporto a soffitto
verniciati di colore nero RAL9017.

*Floor-ceiling lamp.
Sliding sphere on steel cables.
Ground base and ceiling support
painted black RAL9017.*

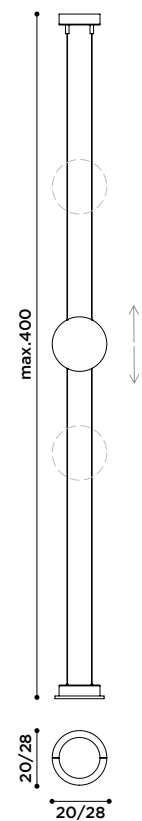

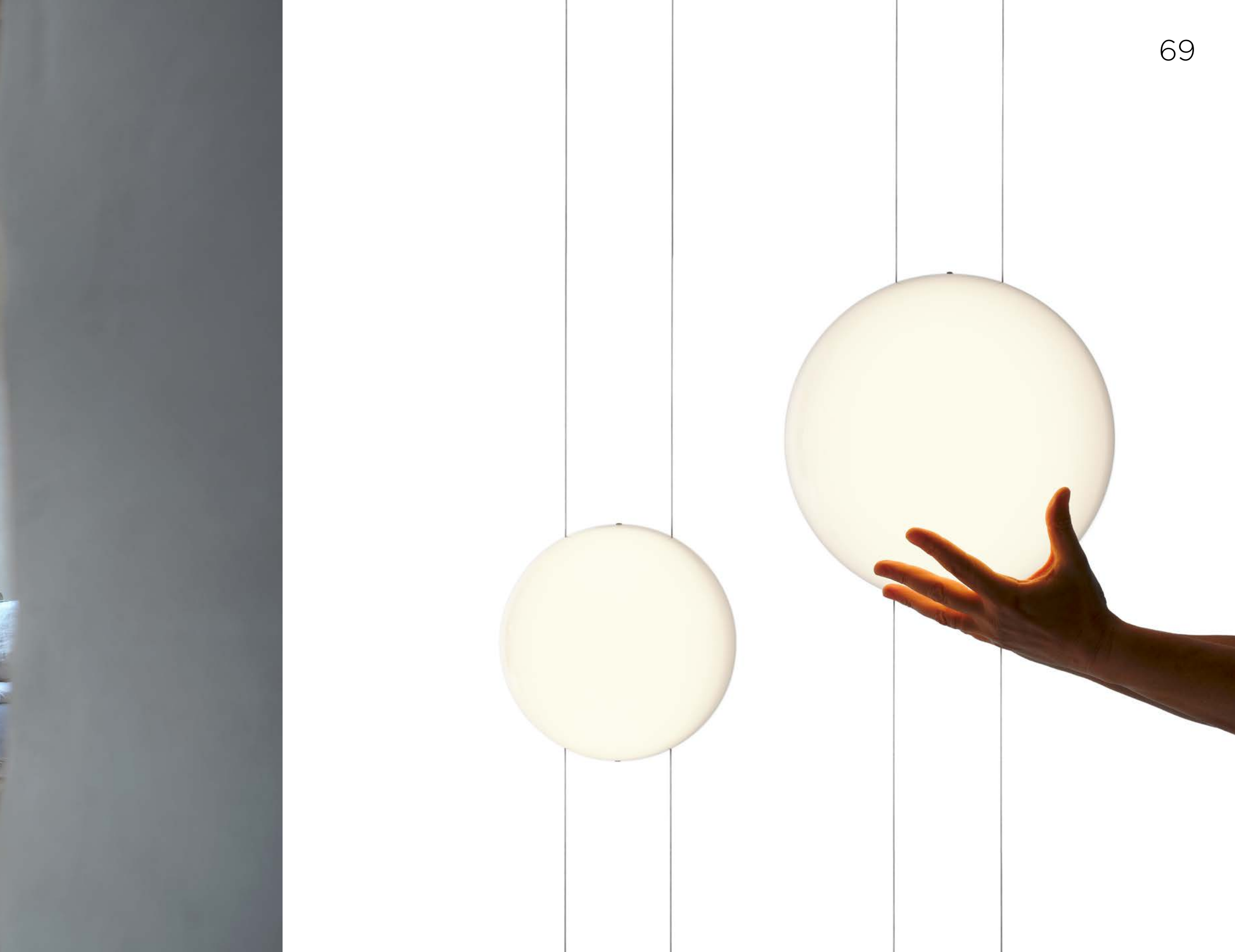





shape
design Uto Balmoral

2024



Tavolo con piano in legno e base in metallo.
Finiture: laccato opaco o lucido in tutti i colori come da campionario o materico spatolato a mano nei colori: bianco, nero, grigio, avorio e terracotta.

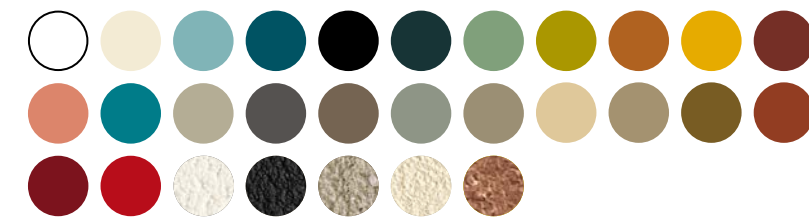
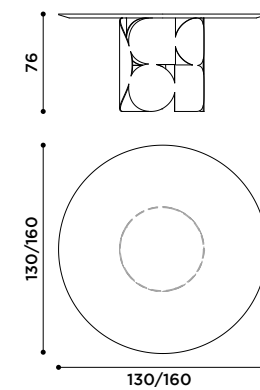
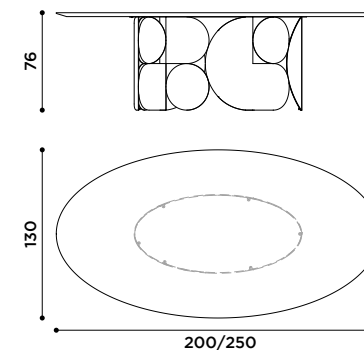
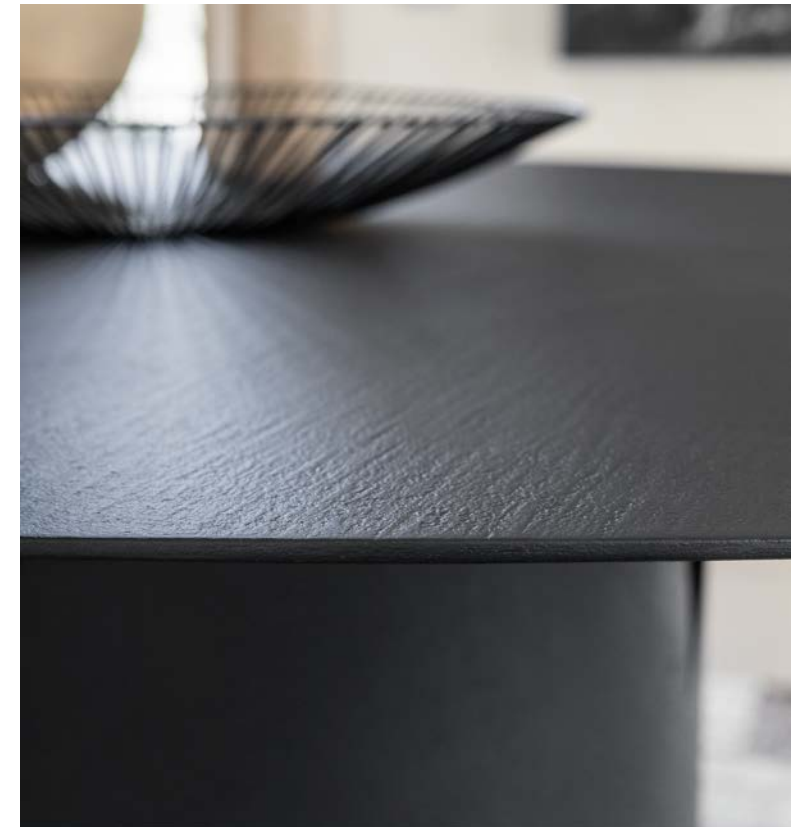
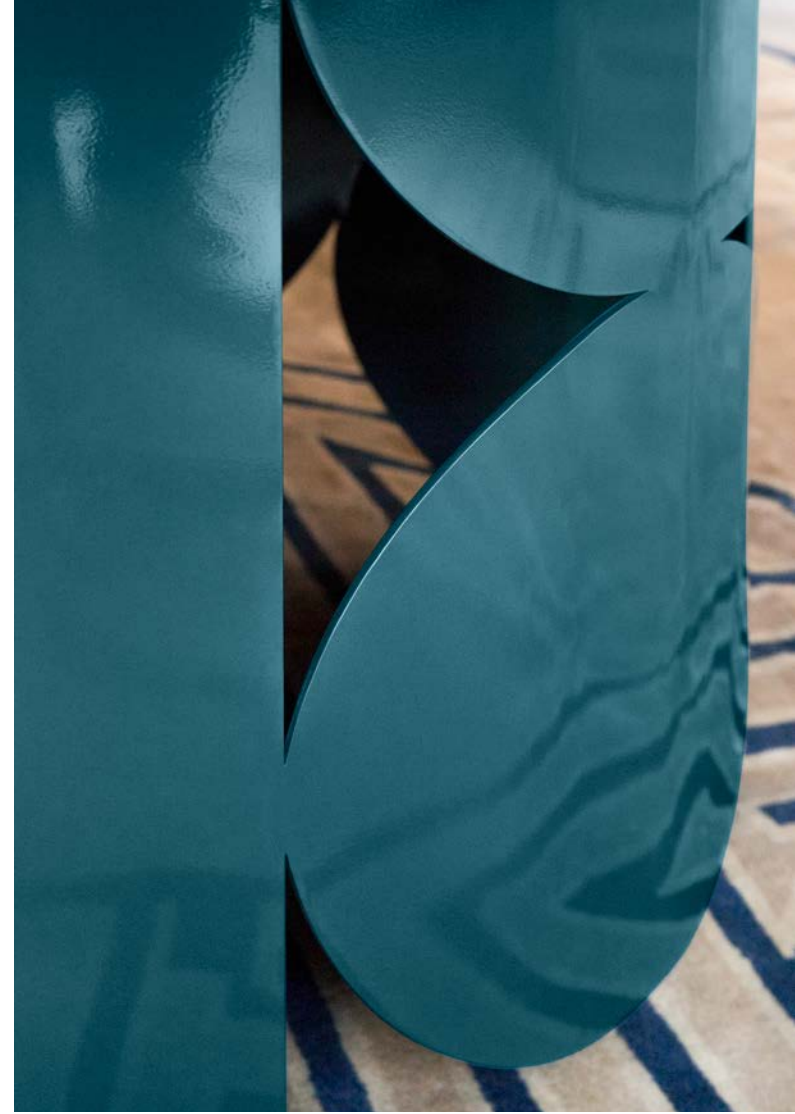

Table with wooden top and metal base.

Finishes: matt or glossy lacquered as colors card or covered with hand-spread materic finish in the colours: white, black, grey, ivory and terracotta.







uccio
design Idelfonso Colombo

2024



Sgabello in alluminio.
Finiture: verniciato nero opaco o
dark bronze.



Aluminium stool.
Finishes: matt black or dark bronze
painted.

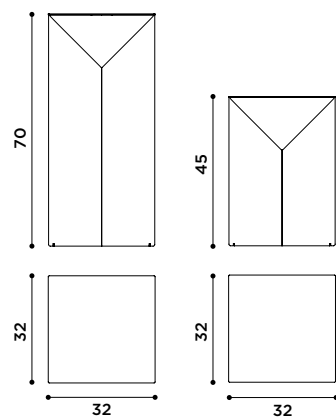

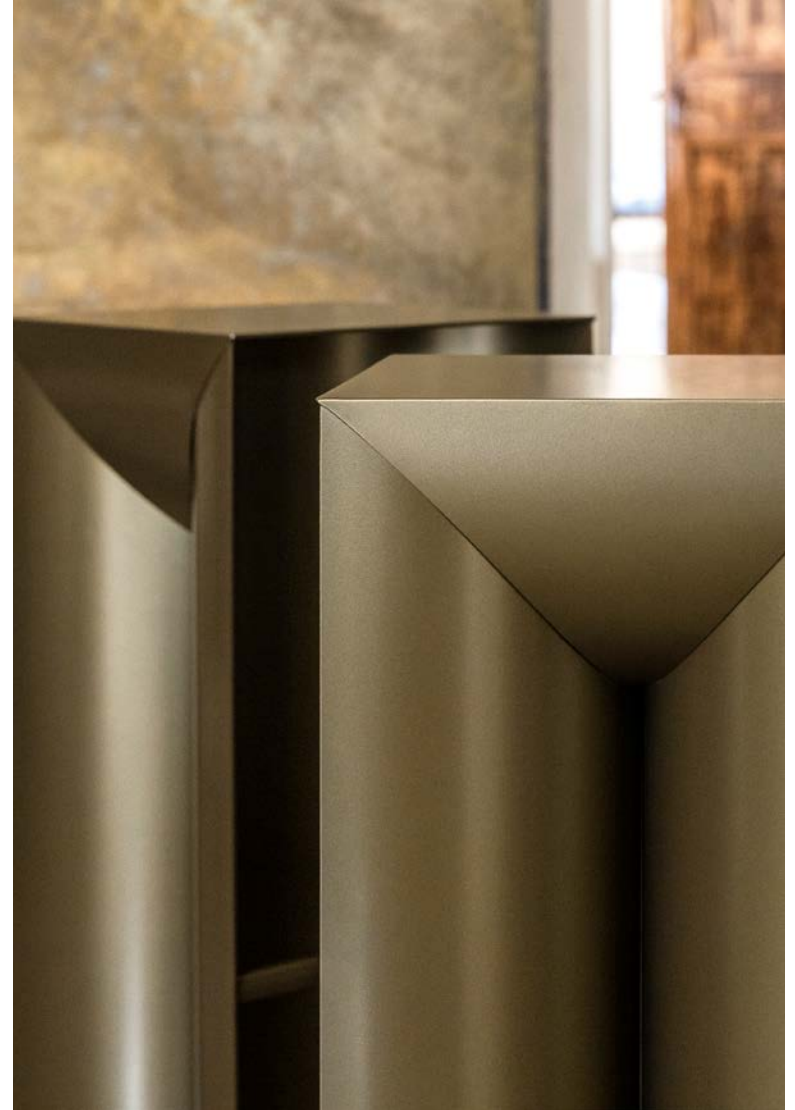



flirt
design Bellavista Piccini

2024



Letto imbottito.
Struttura imbottita con rivestimento
nei tessuti come da campionario.

*Upholstered bed.
Padded structure with cover in
fabrics as per sample card.*

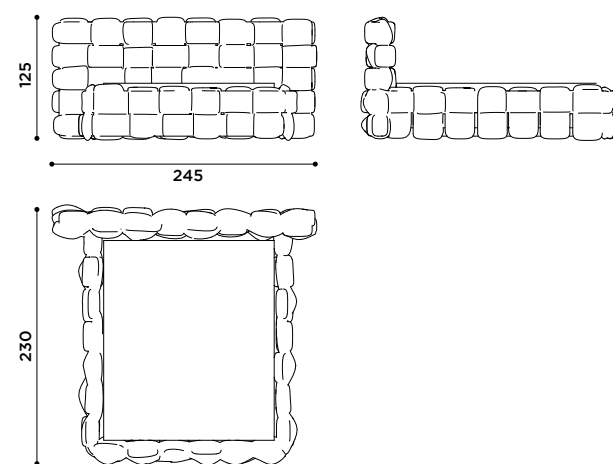





metrica white
design Ctrlzak

2024



Libreria in ferro con ripiani in vetro.
NEW colour: bianco RAL1013.



Iron bookcase with glass shelves.
NEW colour: white RAL1013.

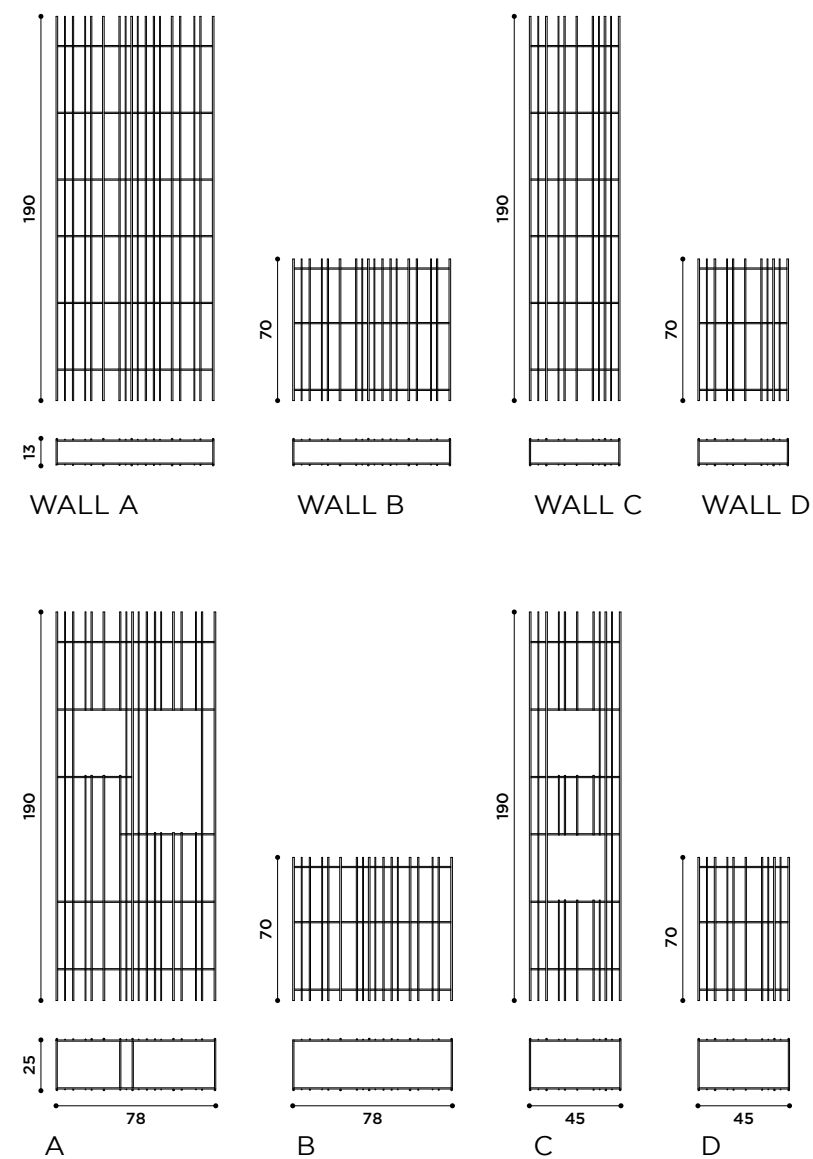



metrica tv
design Ctrlzak

2022



Contenitore porta TV in metallo
con ripiani in vetro.
Finitura: brunito con ripiani in vetro
di colore bronzo.

*Metal TV unit with glass shelves.
Finish: burnished with bronze glass.*

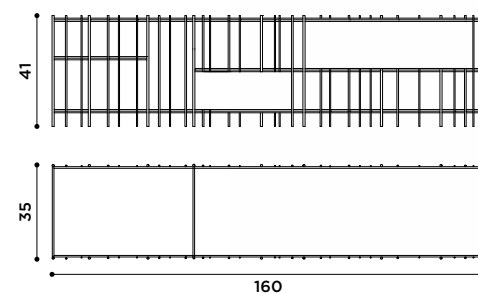



RAL K5 COLORS | 4

La stampa dei colori RAL è indicativa. Si raccomanda la verifica con una cartella RAL ufficiale.
The RAL colors have been matched as closely as possible. Use official RAL Color Publications for most accurate color.



VELLUTI / VELVETS

COMP. 100% PL

I tessuti possono variare di tonalità da una partita all'altra. L'azienda non si assume responsabilità in caso di eventuali differenze di colore. La stampa dei colori è indicativa.
Fabrics can show differences in colours from batch to batch. The company declines any responsibility in case of any colour differences. Colours printing is indicative.



PANNO / FINEST WOOL



COTONE / COTTON

COMP. 100% CO

I tessuti possono variare di tonalità da una partita all'altra. L'azienda non si assume responsabilità in caso di eventuali differenze di colore. La stampa dei colori è indicativa.
Fabrics can show differences in colours from batch to batch. The company declines any responsibility in case of any colour differences. Colours printing is indicative.

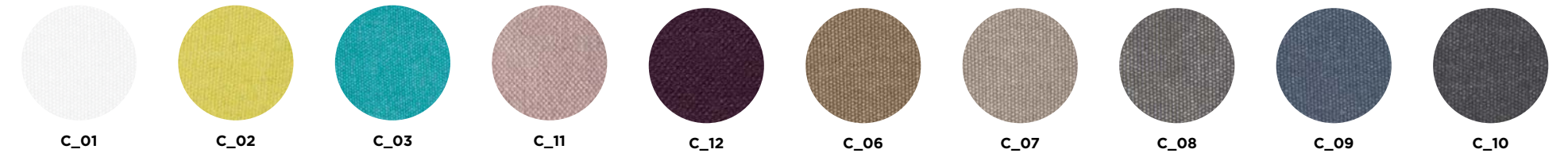

LINO / LINEN

COMP. 100% LI

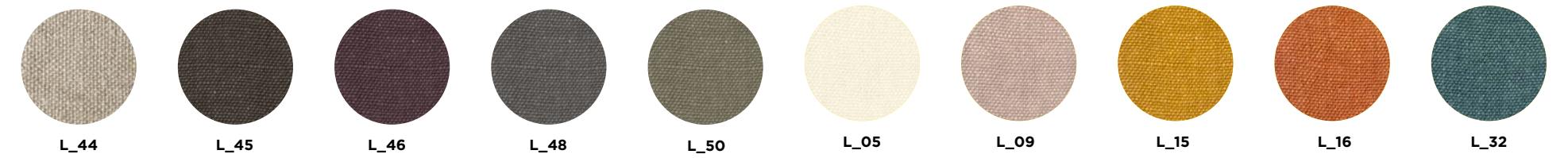

TEXTURE 1

I tessuti possono variare di tonalità da una partita all'altra. L'azienda non si assume responsabilità in caso di eventuali differenze di colore. La stampa dei colori è indicativa.
Fabrics can show differences in colours from batch to batch. The company declines any responsibility in case of any colour differences. Colours printing is indicative.

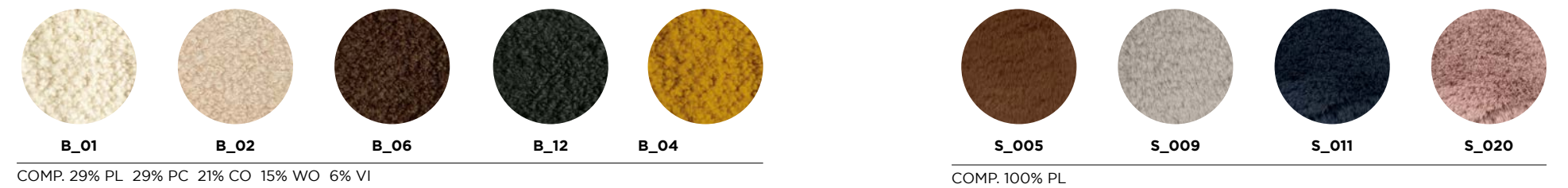

TEXTURE 2

I tessuti possono variare di tonalità da una partita all'altra. L'azienda non si assume responsabilità in caso di eventuali differenze di colore. La stampa dei colori è indicativa.
Fabrics can show differences in colours from batch to batch. The company declines any responsibility in case of any colour differences. Colours printing is indicative.

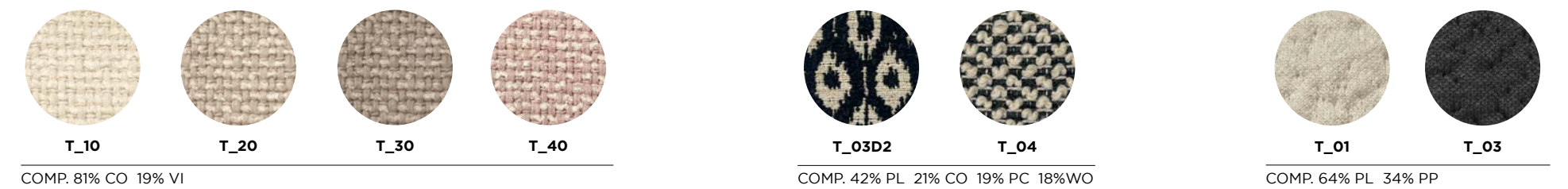

PELLI / LEATHER

Le pelli sono materiali unici. La presenza di piccoli graffi o differenze nell'uniformità sono caratteristiche e pregi della vera pelle e non devono essere considerati difetti. *Leathers are one-of-a-kind materials. The presence of small scratches or scars are characteristics and virtues of true leather and should not be considered defects.*



FONO ASSORBENTI / SOUND-ABSORBING FABRICS COMP. 54% JU 46% LI

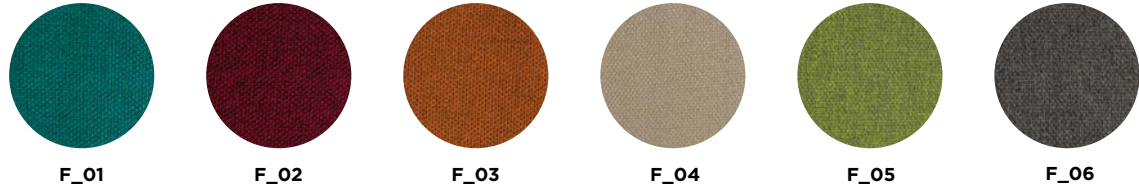

METALLO / METAL

I materiali possono variare di tonalità da una partita all'altra. L'azienda non si assume responsabilità in caso di eventuali differenze di colore. La stampa dei colori è indicativa. *Materials can show differences in colours from batch to batch. The company declines any responsibility in case of any colour differences. Colours printing is indicative.*



LEGNO / WOOD



MATERICI / MATERIALS

I materiali possono variare di tonalità da una partita all'altra. L'azienda non si assume responsabilità in caso di eventuali differenze di colore. La stampa dei colori è indicativa. *Materials can show differences in colours from batch to batch. The company declines any responsibility in case of any colour differences. Colours printing is indicative.*



VETRI / GLASSES



MOGG srl

via A. da Giussano 76
20833 Giussano MB ITALY
t. +39 0362 1723880
info@mogg.it
www.mogg.it

THANKS TO:

Daria Dazzan
Eda Milano
Editions Milano

PROGETTO GRAFICO:

jekyll & hyde

STYLING:

alessandro pasinelli studio

FOTOGRAFIE:

ezio manciucca
tiziano sartorio

POST PRODUCTION E STAMPA:

Azzerboni Printing srl

STAMPA:

Giugno 2024

