













BRANDVAN
® **EGMOND**



2023
EDITION 2



	COLLECTIONS	COLLECTION	TECHNICAL DATA
	BELLA	2	123
	BALLET	10	124
	BUBBLES	18	126
	BUBBLES FLOW	32	128
	BUBBLES SWIRL	46	131
	SOLIS	62	133
	PRIMAVERA	94	140
	PRIMAVERA ICICLES	104	142
	DESERT WIND	108	143
	TAKARA	114	144
	FOUNDER AND DESIGNER WILLIAM BRAND	118	
	OPTIONAL FINISHES	121	
	TECHNICAL INFO	122	
	GENERAL TERMS AND CONDITIONS	146	



Bella

Sculpted by William Brand

Temptation, why resist? As the night proceeds, the last barriers fall. Her necklace, now frozen mid-air yet radiating heat, is captured in Bella.

This floating jewel is a celebration of life, a chic and thoroughly sensual collection of globes and light composed just for your pure delight.

BELC75GSF
Chandelier Vertical
Ø75xH.90 cm, 4x E27, 13 kg, gold satin finish



BELC75GSF
Chandelier Vertical
Ø75xH.90 cm, 4x E27, 13 kg, gold satin finish



Composition of 3 x BELC75N
Chandelier Vertical
Ø75xH.90 cm, 4x E27, 13 kg, nickel finish



BELC75N
Chandelier Vertical
Ø75xH.90 cm, 4x E27, 13 kg, nickel finish



BELC75BDP

Chandelier Vertical

Ø75xH.90 cm, 4x E27, 13 kg, bronze dark patina finish



BELC75BDP

Chandelier Vertical

Ø75xH.90 cm, 4x E27, 13 kg, bronze dark patina finish



BELCHL120BRBUR
Chandelier Horizontal
L.120 x W.60 X H.65 cm, 5x E27, 15 kg, brass burnished finish



BELCHL120BRBUR
Chandelier Horizontal
L.120 x W.60 X H.65 cm, 5x E27, 15 kg, brass burnished finish



Ballet

Sculpted by William Brand

Dancing through the air, the new Ballet exhibits the grandeur and agility of a ballerina.



BALV90BDP

Hanging Lamp Vertical

Ø70xH.90 cm, 2x E27, 7 kg, bronze dark patina finish



BALHL140BDP

Hanging Lamp Horizontal

L.140xW.45xH.50 cm, 2x E27, 11 kg, bronze dark patina finish

Composition of 6xBALV90BDP

Hanging Lamp Vertical

Ø70xH.90 cm, 2x E27, 7 kg, bronze dark patina finish



BALHL140BDP

Hanging Lamp Horizontal

L.140xW.45xH.50 cm, 2x E27, 11 kg, bronze dark patina finish



BALHL140BDP
Hanging Lamp Horizontal
L.140xW.45xH.50 cm, 2x E27, 11 kg, bronze dark patina finish



Composition of 6x BALV90BDP
Hanging Lamp Vertical
Ø70xH.90 cm, 2x E27, 7 kg, bronze dark patina finish



BAL25BDP / BAL35BDP / BAL40BDP
Element
Ø25cm / Ø35cm / Ø40cm, 1x E27, 2 kg, bronze dark patina finish



BALHL140BDP
Hanging Lamp Horizontal
L.140xW.45xH.50 cm, 2x E27, 11 kg, bronze dark patina finish

3xBAL35BDP
Element
Ø35 cm, 1x E27, 2 kg, bronze dark patina finish



Composition of Ballet Elements:

2x BAL25BDP | 1x BAL30BDP | 2x BAL35BDP | 1x BAL40BDP, bronze dark patina finish

CD1-6E-55-BDP

Ceiling cover Disc Ø55 x H.4 cm

On request any composition is possible.



BUBBLES

Sculpted by William Brand

Carefree bliss while blowing bubbles and being mesmerized by the soothing forms and colours. An Eden of lightness and beauty, innocent and unspoiled. The exploration of freedom and experimentation with materials, with almost childlike delight, resulted into the Bubbles collection.



Composition of 3 x BUBH55N
Hanging Lamp
Ø55xH.60 cm, 1x E27, 2,5 kg, nickel finish

Composition of 2 x BUBC75N
Chandelier
Ø75xH.50 cm, 3x E27, 5,5 kg, nickel finish



BUBH55N

Hanging Lamp

Ø55xH.60 cm, 1x E27, 2,5 kg, nickel finish



BUBH55GSF

Hanging Lamp

Ø55xH.60 cm, 1x E27, 2,5 kg, gold satin finish



Composition of 3x BUBC75N
Chandelier
Ø75xH.50 cm, 3x E27, 5,5 kg, nickel finish



Detail of BUBC75N
Chandelier
Ø75xH.50 cm, 3x E27, 5,5 kg, nickel finish



BUBC75N
Chandelier
Ø75xH.50 cm, 3x E27, 5,5 kg, nickel finish



BUBC75BLM
Chandelier
Ø75xH.50 cm, 3x E27, 5,5 kg, black matt finish



BUBC75GSF

Chandelier

Ø75xH.50 cm, 3x E27, 5,5 kg, gold satin finish



BUBC75GSF

Chandelier

Ø75xH.50 cm, 3x E27, 5,5 kg, gold satin finish



Composition of 4xBUBC90GSF
Chandelier
Ø90xH.65 cm, 5x E27, 8 kg, gold satin finish

BUBH55GSF
Chandelier
Ø55xH.60 cm, 1x E27, 2,5 kg, gold satin finish



BUBC90N
Chandelier
Ø90xH.65 cm, 5x E27, 8 kg, nickel finish



BUBHL140N
Hanging Lamp Long
L.140xW.50xH.40 cm, 5x E27, 9 kg, nickel finish



BUBBLES Flow

Sculpted by William Brand

With a burst of boundless vitality, the steel and glass of the Bubbles Flow merge and allow for geometrical forms to be created

BUBFCC90BDP
Chandelier Conical
Ø90xH.140 cm, 6x E27, 15 kg, bronze dark patina finish

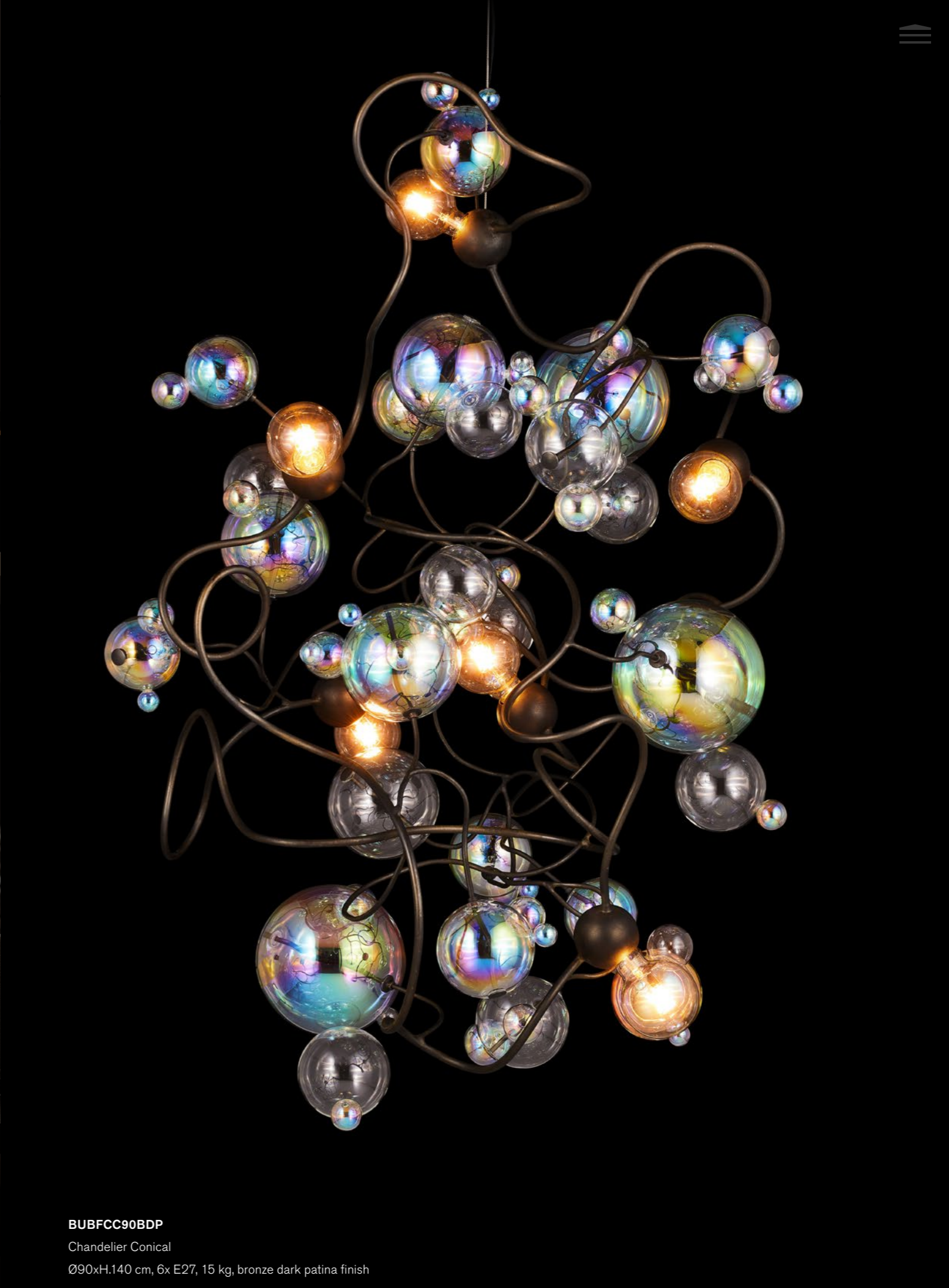

BUBFCC90BDP
Chandelier Conical
Ø90xH.140 cm, 6x E27, 15 kg, bronze dark patina finish



BUBFC120BDP
Chandelier
Ø120xH.70 cm, 6x E27, 16 kg, bronze dark patina finish



NEW



BUBFHL200BDP

Hanging Lamp Long

L.200 x W.45 x H.45 cm, 5x E27, 15,5 kg, bronze dark patina finish



BUBFHL200BDP
Hanging Lamp Long
L.200 x W.45 x H.45 cm, 5x E27, 12,0 kg, bronze dark patina finish



BUBFHL140BDP
Hanging Lamp Long
L.140 x W.45 x H.45 cm, 4x E27, 9,5 kg, bronze dark patina finish

NEW



BUBFHL160BDP
Hanging Lamp Long
L.160 x W.45 x H.45 cm, 4x E27, 10,0 kg, bronze dark patina finish

NEW



BUBFHL120GSF
Hanging Lamp Long
L.120 x W.45 x H.45 cm, 3x E27, 9,0 kg, gold satin finish



BUBFP65BDP
Ceiling Lamp
Ø65xH.35 cm, 3x E27, 6 kg, bronze dark patina finish



BUBFP90BDP
Ceiling Lamp
Ø90xH.35 cm, 5x E27, 10 kg, bronze dark patina finish



BUBBLES Swirl

Sculpted by William Brand

Independent in spirit and amorphous by heart, the Bubbles Swirl allows for stunning cloud like shapes to be composed.



BUBSOBJ160BDP
Sculptural Object
W.160xD.120xH.190 cm, 7x E27, 23 kg, bronze dark patina finish

BUBHL140BLM
Hanging Lamp Long
L.140xW.50xH.40 cm, 5x E27, 9 kg, black matt finish



BUBSOBJ160BDP
Sculptural Object
W.160xD.120xH.190 cm, 7x E27, 23 kg, bronze dark patina finish





BUBFHL160BDP
Hanging Lamp Long
L.160 x W.45 x H.45 cm, 4x E27, 10,0 kg, bronze dark patina finish

Composition of BUBSOBJ100BDP
Sculptural Object
W.100 x D.80 x H.100 cm, 3x E27, 11,0 kg, bronze dark patina finish

BUBSOBJ130BDP
Sculptural Object
W.130 x D.100 x H.150 cm, 5x E27, 16,0 kg, bronze dark patina finish

BUBSOBJ160BDP
Sculptural Object
W.160 x D.120 x H.190 cm, 7x E27, 23,0 kg, bronze dark patina finish



BUBSOBJ160GSF
Sculptural Object
W.160 x D.120 x H.190 cm, 7x E27, 23,0 kg, gold satin finish



BUBSOBJ130BDP

Sculptural Object

W.130 x D.100 x H.150 cm, 5x E27, 16,0 kg, bronze dark patina finish



BUBSOBJ100BDP

Sculptural Object

W.100xD.80xH.100 cm, 3x E27, 11 kg, bronze dark patina finish



Composition of 5 x BUBSH50BDP

Hanging Lamp

W.50xD.40xH.50 cm, 1x E27, 3 kg, bronze dark patina finish



BUBSH50BDP

Hanging Lamp

W.50xD.40xH.50 cm, 1x E27, 3 kg, bronze dark patina finish





BUBSH50BDP

Hanging Lamp

W.50 x D.40 x H.50 cm, 1x E27, 3,0 kg, bronze dark patina finish



Composition of 5x BUBSH50BDP

Hanging Lamp

W.50 x D.40 x H.50 cm, 1x E27, 3,0 kg, bronze dark patina finish



BUBSH50GSF

Hanging Lamp

W.50 x D.40 x H.50 cm, 1x E27, 3,0 kg, gold satin finish



BUBSH50GSF

Hanging Lamp

W.50 x D.40 x H.50 cm, 1x E27, 3,0 kg, gold satin finish

BUBSH50BDP

Hanging Lamp

W.50 x D.40 x H.50 cm, 1x E27, 3,0 kg, bronze dark patina finish

NEW



BUBSH40BDP

Hanging Lamp

W.40 x D.35 x H.35 cm, 1x E27, 2,0 kg, bronze dark patina finish



Composition of 3x BUBSH40BDP

Hanging Lamp

W.40 x D.35 x H.35 cm, 1x E27, 2,0 kg, bronze dark patina finish

IL1-3E-100-BDP

Ceiling cover In Line L.100 x W.10 x H.2,5 cm, bronze dark patina finish



Composition of 3x BUBSH40BDP

Hanging Lamp
W.40 x D.35 x H.35 cm, 1x E27, 2,0 kg, bronze dark patina finish

IL1-3E-100-BDP

Ceiling cover In Line L.100 x W.10 x H.2,5 cm, bronze dark patina finish

BUBSOBJ130BDP

Sculptural Object

W.130 x D.100 x H.150 cm, 5x E27, 16,0 kg, bronze dark patina finish



Composition of 3x BUBSH40BDP

Hanging Lamp
W.40 x D.35 x H.35 cm, 1x E27, 2,0 kg, bronze dark patina finish

CD1-3E-50-BDP

Ceiling cover Disc Ø50,0 x H.4 cm, bronze dark patina finish



Solis

Sculpted by William Brand

Just as the sun's gravity keeps other planets from spinning into deep space, the Solis pulls your eyes towards the seductive composition of different reflections.

SOLCC70BDP
Chandelier Conical
Ø70xH.80 cm, 12x E14, 21,0 kg, bronze dark patina finish reflectors



SOLCC70BDP-ST
Chandelier Conical
Ø70xH.80 cm, 12x E14, 21,0 kg, bronze dark patina finish finish with stainless steel reflectors





SOLCC70BDP-BR BUR

Chandelier Conical

Ø70xH.80 cm, 12x E14, 21,0 kg, bronze dark patina finish with brass burnished reflectors



SOLOC120BLM-BDP

Chandelier Oval

L.120xW.70xH.50 cm, 12x E14, 20,0 kg, black matt finish with bronze dark patina finish reflectors



SOLOC120BLM-GSF

Chandelier Oval

L.120xW.70xH.50 cm, 12x E14, 20,0 kg, black matt finish with gold satin reflectors



SOLOC120BLM-GSF

Chandelier Oval

L.120xW.70xH.50 cm, 12x E14, 20,0 kg, black matt finish with gold satin reflectors



SOLOC120BLM-BR BUR

Chandelier Oval

L.120xW.70xH.50 cm, 12x E14, 20,0 kg, black matt finish with brass burnished reflectors



SOLOC120BLM-BR BUR

Chandelier Oval

L.120xW.70xH.50 cm, 12x E14, 20,0 kg, black matt finish with brass burnished reflectors





SOLC100BDP
Chandelier Round
Ø100xH.55 cm, 12x E14, 22,0 kg, bronze dark patina finish



SOLC100BDP
Chandelier Round
Ø100xH.55 cm, 12x E14, 22,0 kg, bronze dark patina finish



SOLC100BDP-ST

Chandelier Round

Ø100xH.55 cm, 12x E14, 22,0 kg, bronze dark patina finish with stainless steel reflectors



SOLC100BDP-GSF

Chandelier Round

Ø100xH.55 cm, 10x E14, 22,0 kg, bronze dark patina finish with gold satin reflectors



SOLC100BDP-BRBUR

Chandelier Round

Ø100xH.55 cm, 10x E14, 22,0 kg, bronze dark patina finish with brass burnished reflectors



SOLH55BLM-ST
Hanging Lamp
Ø55xH.40 cm, 5x E14, 7,0 kg, black matt finish with stainless steel reflectors



2x SOLH55BLM-ST
Hanging Lamp
Ø55xH.40 cm, 5x E14, 7,0 kg, black matt finish with stainless steel reflectors



SOLH65BDP-ST
Hanging Lamp
Ø65xH.40 cm, 5x E14, 7,0 kg, bronze dark patina finish with stainless steel reflectors



Customised finish SOLH40N-ST

Hanging Lamp

Ø40xH.30 cm, 5x E14, 5,0 kg, nickel finish with stainless steel reflectors

New Collections 2023



SOLH55BLM-BDP

Hanging Lamp

Ø55xH.40 cm, 5x E14, 7,0 kg, black matt finish with bronze dark patina reflectors

New Collections 2023

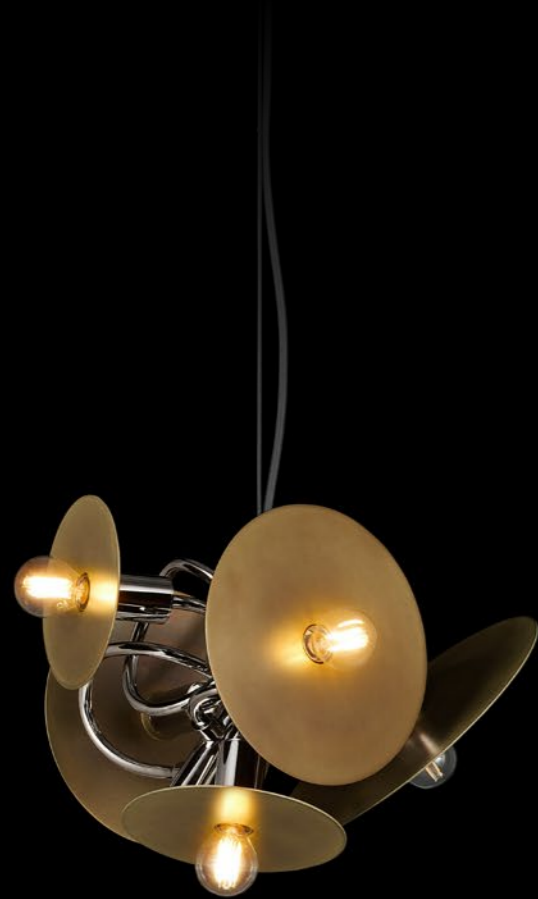

Customized finish SOLH40N-BRBUR

Hanging Lamp
Ø40xH.30 cm, 5x E14, 5,0 kg, nickel finish with
brass burnished reflectors

SOLH55BLM-BRBUR

Hanging Lamp
Ø55xH.40 cm, 5x E14, 7,0 kg, black matt finish with
brass burnished reflectors

SOLH65BDP-BRBUR

Hanging Lamp
Ø65xH.40 cm, 5x E14, 7,0 kg, bronze dark patina finish with brass burnished reflectors



SOLH65BDP-ST

Hanging Lamp

Ø65xH.40 cm, 5x E14, 7,0 kg, bronze dark patina finish with stainless steel reflectors



SOLH65BDP

Hanging Lamp

Ø65xH.40 cm, 5x E14, 7,0 kg, bronze dark patina finish with bronze dark patina reflectors



SOLHL125BLM-BDP
Hanging Lamp Long
L.125xW.45xH.40 cm, 12x E14, 15,5 kg, black matt finish with bronze dark patina reflectors



SOLHL125BLM-BDP
Hanging Lamp Long
L.125xW.45xH.40 cm, 12x E14, 15,5 kg, black matt finish with bronze dark patina reflectors



SOLHL125BLM-BR BUR

Hanging Lamp Long

L.125xW.45xH.40 cm, 12x E14, 15,5 kg, black matt finish with brass burnished reflectors



Customised finish SOLV150GSF

Hanging Lamp Vertical

Ø50xH.150 cm, 14x E14, 17 kg, bronze dark patina finish with gold satin reflectors



Customised finish SOLV150GSF-BLM

Hanging Lamp Vertical

Ø50xH.150 cm, 14x E14, 17 kg, bronze dark patina finish with black matt reflectors



SOLF200BDP
Floor Lamp
Ø50xH.200 cm, 7x E14, 27 kg, bronze dark patina finish



SOLF200BDP-BR BUR
Floor Lamp
Ø50xH.200 cm, 7x E14, 27 kg, bronze dark patina finish with
brass burnished reflectors



SOLF200BDP-ST
Floor Lamp
Ø50xH.200 cm, 7x E14, 27 kg, bronze dark patina finish with
stainless steel reflectors



Customized finish SOLT75N-BDP
Table Lamp
Ø40xH.75 cm, 5x E14, 10 kg, nickel finish with
bronze dark patina finish



Customized finish SOLT75N-ST
Table Lamp
Ø40xH.75 cm, 5x E14, 10 kg, nickel finish with
stainless steel reflectors



SOLP35BDP-ST
Ceiling Lamp
Ø35xH.20 cm, 3x E14, 5 kg, bronze dark patina finish with stainless steel reflectors



SOLP35BDP-BRBRUR
Ceiling Lamp
Ø35xH.20 cm, 3x E14, 5 kg, bronze dark patina finish with brass burnished reflectors



SOLP35BDP
Ceiling Lamp
Ø35xH.20 cm, 3x E14, 5 kg, bronze dark patina finish with bronze dark patina finish reflectors



SOLW35BDP
Wall Lamp
Ø35xH.20 cm, 3x E14, 5 kg, bronze dark patina finish



SOLW35BDP-BRBRUR
Wall Lamp
Ø35xH.20 cm, 3x E14, 5 kg, bronze dark patina finish with brass burnished reflectors



SOLP65BDP-ST
Ceiling Lamp
Ø65xH.25 cm, 5x E14, 8 kg, bronze dark patina finish with stainless steel reflectors



SOLP90BDP-GSF
Ceiling Lamp
Ø90xH.25 cm, 5x E14, 10 kg, bronze dark patina finish with gold satin reflectors



CEILING LAMPS SOLP65 AND SOLP90 CAN BE USED AS WALL OBJECTS
Wall Lamp
Ø90xH.25 cm, 5x E14, 10 kg, bronze dark patina finish with gold satin reflectors



Primavera

Sculpted by William Brand

Merging after the long winter cold, the first rays of spring warm the Earth and all she carries. The old tree, overgrown with years and ice, has survived and will thrive once again.



PRI30BRBUR
Element
Chandelier
Ø30xH.80 cm , 3x G9 , 4,5 kg , brass burnished finish

PRIC60BRBUR
Chandelier
Ø60xH.92 cm , 6x G9 , 13,5 kg , brass burnished finish



PRIC90GSF
Chandelier
Ø90xH.107 cm , 12x G9 , 25 kg , gold satin finish



PRIC90WM

Chandelier

Ø90xH.107 cm , 12x G9 , 25 kg , white matt finish



PRIC60BLM

Chandelier

Ø60xH.92 cm , 6x G9 , 13,5 kg , black matt finish





PRIC60BRBUR

Chandelier

Ø60xH.92 cm , 6x G9 , 13,5 kg , brass burnished finish



PRI30GSF

Element

Ø30xH.80 cm , 3x G9 , 4,5 kg , gold satin finish





Composition of 3x PRI30BDP

Element

Ø30 x H.80 cm, 3x G9, 4,5 kg, bronze dark patina finish

IL1-3E-100-BDP

Ceiling cover In Line L.100 x W.10 x H.2,5 cm, bronze dark patina finish



Composition of 3x PRI30BDP

Element

Ø30 x H.80 cm, 3x G9, 4,5 kg, bronze dark patina finish

CD1-3E-50-BDP

Ceiling cover Disc Ø50,0 x H.4 cm, bronze dark patina finish



PRIW50BRBUR

Wall Lamp

W.10xH.52xD.17 cm , 1x G9 , 4 kg , brass burnish finish

New Collections 2023



PRIW50BDP

Wall Lamp

W.10xH.52xD.17 cm , 1x G9 , 4 kg , bronze dark patina finish



PRIW50BLM

Wall Lamp

W.10xH.52xD.17 cm , 1x G9 , 4 kg , black matt finish

New Collections 2023





Primavera Icicles

Sculpted by William Brand

Create your own composition of light, glass and splendour.

The hollow Icicles, available in 35 and 50 cm height, can be used to create any formation you wish for.

An installation of magnificence for a grand lobby or a subtle composition over a table?

All possibilities are within reach with the Primavera Icicles.



Composition of PRISI35N and PRISI50N

Element

Ø10xH.35 cm, 1x G9, 1 kg, nickel finish and Ø10xH.50 cm, 1x G9, 1 kg, nickel finish



Composition of PRISI35N and PRISI50N

Element

Ø10xH.35 cm, 1x G9, 1 kg, nickel finish and Ø10xH.50 cm, 1x G9, 1 kg, nickel finish



Composition of PRISI35N and PRISI50N

Element

Ø10xH.35 cm, 1x G9, 1 kg, nickel finish and Ø10xH.50 cm, 1x G9, 1 kg, nickel finish



Composition of PRISI50N

Element

Ø10xH.50 cm, 1x G9, 1 kg, nickel finish



Desert Wind

Sculpted by William Brand

Raw yet elegant, the Desert Wind draws from the same journey to Namibia of founder William Brand that led to other collections from his hand. Yesterday and tomorrow cross and merge into this lighting sculpture, both lost in the haze of the warming light.

DEWCC80BLM
Chandelier Conical
Ø80xH.80 cm , 9x G14 , 22 kg , black matt finish

SOLW35BDP
Wall Lamp
Ø35xH.20 cm , 3x E14 , 5 kg , bronze dark patina finish



DEWCC80GSF
Chandelier Conical
Ø80xH.80 cm , 9x G14 , 22 kg , gold satin finish



DEWOC140BLM

Chandelier Oval

L.140xW.65xH.55 cm , 10x E14 , 27 kg , black matt finish





DEWC125BLM

Chandelier Round

Ø125xH.55 cm , 11x E14 , 25 kg , black matt finish



TAKARA

Sculpted by William Brand

The Takara, Japanese for treasure, is a sculptural and evocative piece of art that is at the same time functional.

Casted in bronze, crafted by hand and created for generations to come.



TAKHL200BDP

Hanging Lamp Long

L.194xW.18xH.14 cm , 2x LED STRIPE L. 150CM , 27 kg , cast bronze dark patina finish



TAKHL150BDP

Hanging Lamp Long
L.142xW.12xH.14 cm , 2x LED STRIPE L. 100CM , 21 kg , cast bronze dark patina finish



TAKHL200BDP

Hanging Lamp Long
L.194xW.18xH.14 cm , 2x LED STRIPE L. 150CM , 27 kg , cast bronze dark patina finish





William Brand

founder / designer

William Brand – an award-winning designer, sculptor - is widely recognised for his imaginative and daring sculptural lighting. He was trained as an artist and an architect. He graduated at the academy of fine arts and design. His lighting sculptures, often perceived as art pieces, grace the finest residences, exclusive boutiques, stunning hotels and leading art exhibitions.

His interior designs are minimalist, in contrast to his lighting designs which have a powerful sculptural presence. His way of working is quite specific. Immediately after defining the concept he starts working like a sculptor; experimenting and crafting while having the object sculpting in his hands, often with unexpected results. Therefore the journey is just as exciting and important as the destination.

Optional finishes



Architects and other co-creatives are invited to discover the endless possibilities of customising our lighting sculptures.

We hope to inspire you through the different colours and forms of various compositions, just as we enjoy being stimulated by your requests. William Brand's background in architecture gives him the insight to fully understand the demands and challenges of your work. Combined with his experience he is the perfect partner to translate your needs into handcrafted reality.

For our clients we not only customise to different dimensions, but also in different finishes: allowing for a truly personal lighting sculpture to be created.

The possibilities with our lighting sculptures are, in fact, limitless.

We would like to show some of the new possibilities.

001 Nickel (N)	002 Black Matt (BLM)	003 Black High Gloss (BL)	004 White Matt (WM)	005 White High Gloss (W)
008 Bronze (B)	010 Brass High Gloss (BR)	011 Stainless Steel (ST)	012 Brass Aged (BRA)*	013 Copper High Gloss (COP)
015 Silver Colour leaf (SL)	016 Gold Colour leaf (GL)	017 Brass Grinded (BRG)	019 Brass Burnished (BRBUR)*	019 Brass Burnished (BRBUR)* with nano wax coating
020 Copper Burnished (COPBUR)*	020 Copper Burnished (COPBUR)* with nano wax coating	021 Gold Colour (GC)	022 Nickel Aged Cool (NAC)*	023 Brass Aged Colour (BRAC)
024 Gold Satin (GSF)	025 Copper Satin (COPSF)	026 Nickel Aged Warm (NAW)*	027 Bronze dark patina finish (BDP)*	

* Due to the unique process of creating the finishes Brass Burnished, Brass Aged, Nickel Aged, Copper Burnished and Bronze dark patina finish lights that will be combined in the same space should be ordered at the same time, in order to prevent lights from looking slightly different from each other. Colours and finishes may appear slightly different by viewing in print or on screens.

Technical information



Collection Bella

Chandelier

Art.nr.	Dimensions	Light bulb	Weight	Finish
BELC75BLM	Ø75xH.90 cm	4x E27	13,0 kg	black matt finish
BELC75BDP	Ø75xH.90 cm	4x E27	13,0 kg	bronze dark patina finish
BELC75N	Ø75xH.90 cm	4x E27	13,0 kg	nickel finish
BELC75BRBUR	Ø75xH.90 cm	4x E27	13,0 kg	brass burnished finish
BELC75GSF	Ø75xH.90 cm	4x E27	13,0 kg	gold satin finish

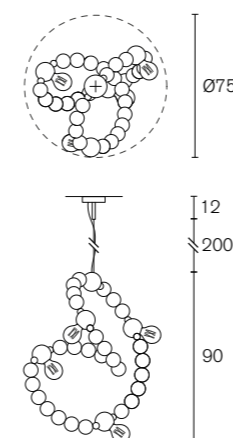

Chandelier Horizontal

Art.nr.	Dimensions	Light bulb	Weight	Finish
BELCHL120BLM	L.120xW.60xH.65 cm	5x E27	15,0 kg	black matt finish
BELCHL120BDP	L.120xW.60xH.65 cm	5x E27	15,0 kg	bronze dark patina finish
BELCHL120N	L.120xW.60xH.65 cm	5x E27	15,0 kg	nickel finish
BELCHL120BRBUR	L.120xW.60xH.65 cm	5x E27	15,0 kg	brass burnished finish
BELCHL120GSF	L.120xW.60xH.65 cm	5x E27	15,0 kg	gold satin finish

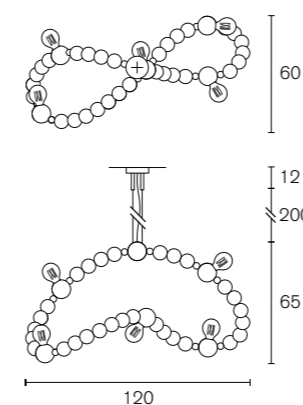

All Chandeliers are supplied with 2 meter steel cable, 2 meter electrical cable and a ceiling cover.

Collection Ballet

Hanging Lamp Vertical

Art.nr.	Dimensions	Light bulb	Weight	Finish
BALV90BDP	Ø70xH.90 cm	2x E27	7,0 kg	bronze dark patina finish

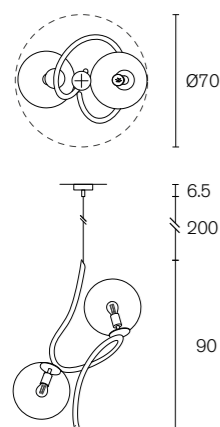

Hanging Lamp Horizontal

Art.nr.	Dimensions	Light bulb	Weight	Finish
BALHL140BDP	L.140xW.45xH.50 cm	2x E27	11,0 kg	bronze dark patina finish

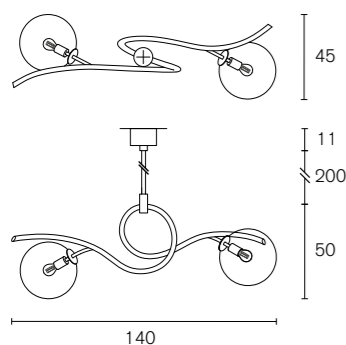

All Hanging Lamps Vertical and Elements are supplied with 2 meter electrical cable and a ceiling cover.
All Hanging Lamps Horizontal are supplied with 2 meter stem and a ceiling cover.

Collection Ballet

Element

Art.nr.	Dimensions	Light bulb	Weight	Finish
BAL25BDP	Ø25 cm	1x E27	2,0 kg	bronze dark patina finish
BAL30BDP	Ø30 cm	1x E27	2,5 kg	bronze dark patina finish
BAL35BDP	Ø35 cm	1x E27	3,0 kg	bronze dark patina finish
BAL40BDP	Ø40 cm	1x E27	3,5 kg	bronze dark patina finish

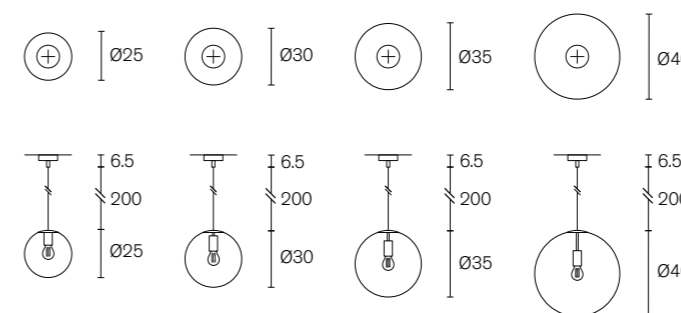

Suspension options

The Ballet collection contains various elements that give a possibility to merge different objects into compositions. Number of elements, total drop, and total volume of compositions can be customised. Several measurements change with number and size of chosen Elements.

Standard the compositions will be delivered with ceiling covers in the finish of the lamps.

The ceiling covers In Line and Disc can be delivered in various finishes on request.

In Line IL1-3E-100 (120 | 140)
Composition of equal elements
BAL30 or BAL35
x3 Elements

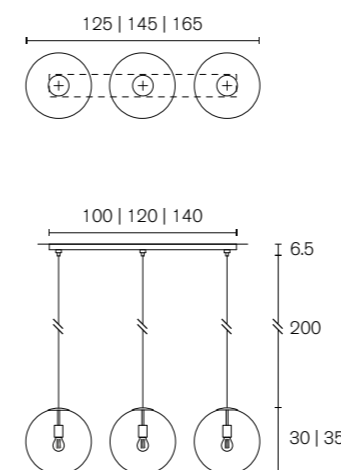

In Line IL1-5E-150
Composition of mixed elements
x5 Elements Ø25 | 30 | 35 | 40

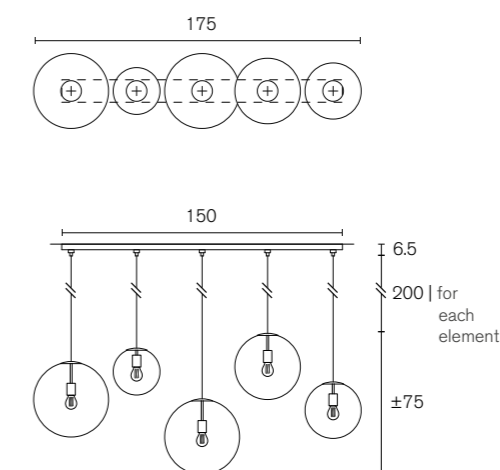

Disc CD1-6E-55
Composition of equal elements
x6 Elements Ø25 | 30 | 35 | 40

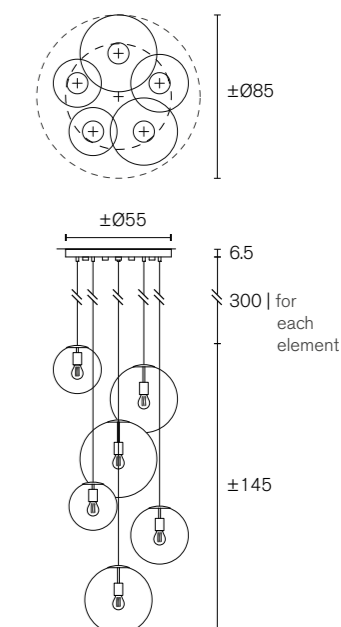

All Elements are supplied with 2 meter electrical cable and a ceiling cover.
For Compositions of Elements customised ceiling covers can be offered.
Standard glass spheres for Ballet lamps and Elements are iridescent.

Collection Bubbles

Hanging Lamp

Art.nr.	Dimensions	Light bulb	Weight	Finish
BUBH55BLM	Ø55xH.60 cm	1x E27	2,5 kg	black matt finish
BUBH55BDP	Ø55xH.60 cm	1x E27	2,5 kg	bronze dark patina finish
BUBH55N	Ø55xH.60 cm	1x E27	2,5 kg	nickel finish
BUBH55BRBUR	Ø55xH.60 cm	1x E27	2,5 kg	brass burnished finish
BUBH55GSF	Ø55xH.60 cm	1x E27	2,5 kg	gold satin finish

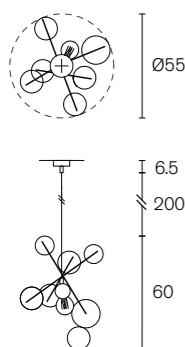

Chandelier

Art.nr.	Dimensions	Light bulb	Weight	Finish
BUBC75BLM	Ø75xH.50 cm	3x E27	5,5 kg	black matt finish
BUBC75BDP	Ø75xH.50 cm	3x E27	5,5 kg	bronze dark patina finish
BUBC75N	Ø75xH.50 cm	3x E27	5,5 kg	nickel finish
BUBC75BRBUR	Ø75xH.50 cm	3x E27	5,5 kg	brass burnished finish
BUBC75GSF	Ø75xH.50 cm	3x E27	5,5 kg	gold satin finish
BUBC90BLM	Ø90xH.65 cm	5x E27	8 kg	black matt finish
BUBC90BDP	Ø90xH.65 cm	5x E27	8 kg	bronze dark patina finish
BUBC90N	Ø90xH.65 cm	5x E27	8 kg	nickel finish
BUBC90BRBUR	Ø90xH.65 cm	5x E27	8 kg	brass burnished finish
BUBC90GSF	Ø90xH.65 cm	5x E27	8 kg	gold satin finish

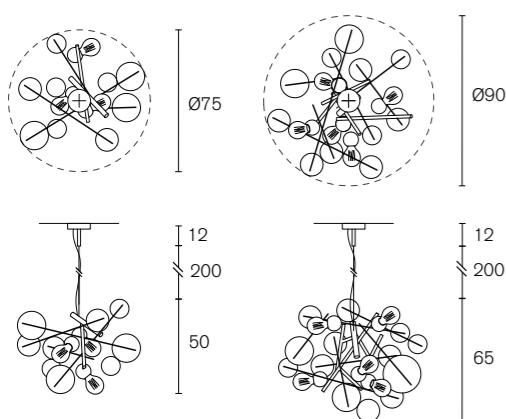

All Hanging Lamps and Chandeliers are supplied with 2 meter steel cable (when required), 2 meter electrical cable and a ceiling cover.
Standard glass spheres for the Bubbles are iridescent (major) mixed with clear.

Collection Bubbles

Hanging Lamp Long

Art.nr.	Dimensions	Light bulb	Weight	Finish
BUBHL140BLM	L.140xW.50xH.40 cm	5x E27	9 kg	black matt finish
BUBHL140BDP	L.140xW.50xH.40 cm	5x E27	9 kg	bronze dark patina finish
BUBHL140N	L.140xW.50xH.40 cm	5x E27	9 kg	nickel finish
BUBHL140BRBUR	L.140xW.50xH.40 cm	5x E27	9 kg	brass burnished finish
BUBHL140GSF	L.140xW.50xH.40 cm	5x E27	9 kg	gold satin finish

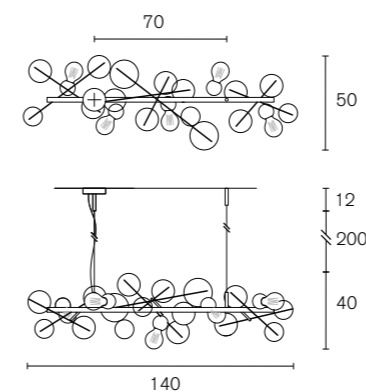

All Hanging Lamps Long are supplied with 2 meter steel cables, 2 meter electrical cable and a ceiling cover.
Standard glass spheres for the Bubbles are iridescent (major) mixed with clear.

Collection Bubbles Flow

Chandelier Conical

Art.nr.	Dimensions	Light bulb	Weight	Finish
BUBFCC70BDP	Ø70xH.100 cm	4x E27	8,0 kg	bronze dark patina finish
BUBFCC70GSF	Ø70xH.100 cm	4x E27	8,0 kg	gold satin finish
BUBFCC80BDP	Ø80xH.120 cm	5x E27	11,0 kg	bronze dark patina finish
BUBFCC80GSF	Ø80xH.120 cm	5x E27	11,0 kg	gold satin finish
BUBFCC90BDP	Ø90xH.140 cm	6x E27	15,0 kg	bronze dark patina finish
BUBFCC90GSF	Ø90xH.140 cm	6x E27	15,0 kg	gold satin finish

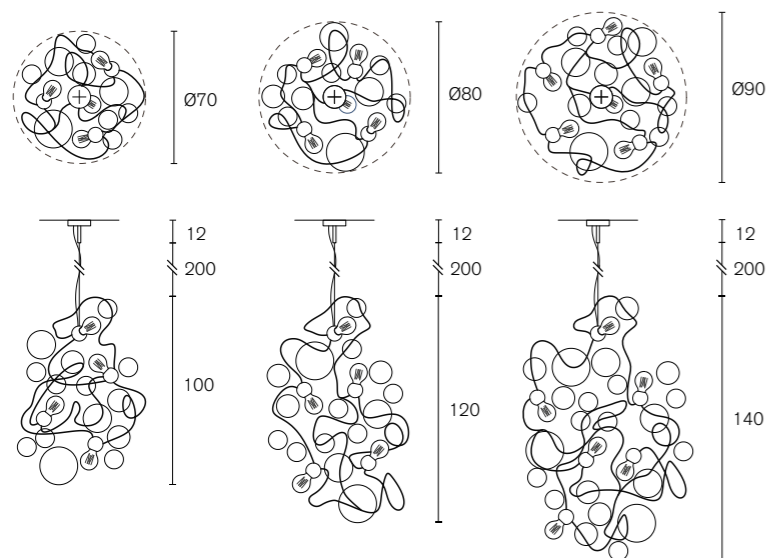

Chandelier Round

Art.nr.	Dimensions	Light bulb	Weight	Finish
BUBFC80BDP	Ø80xH.50 cm	4x E27	8,0 kg	bronze dark patina finish
BUBFC80GSF	Ø80xH.50 cm	4x E27	8,0 kg	gold satin finish
BUBFC100BDP	Ø100xH.60 cm	5x E27	12,0 kg	bronze dark patina finish
BUBFC100GSF	Ø100xH.60 cm	5x E27	12,0 kg	gold satin finish
BUBFC120BDP	Ø120xH.70 cm	6x E27	16,0 kg	bronze dark patina finish
BUBFC120GSF	Ø120xH.70 cm	6x E27	16,0 kg	gold satin finish

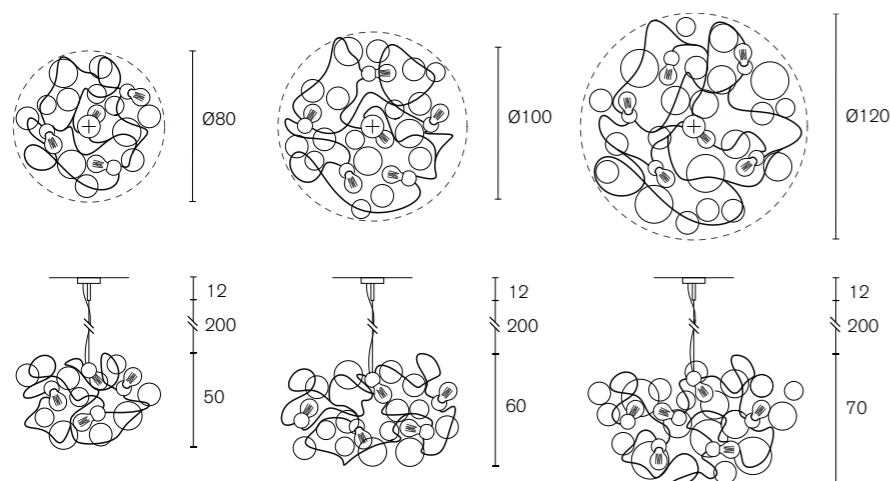

All Chandeliers are supplied with 2 meter steel cable, 2 meter electrical cable and a ceiling cover.
Standard glass spheres for the Bubbles Flow are iridescent (major) mixed with clear.

Collection Bubbles Flow

Hanging Lamp

Art.nr.	Dimensions	Light bulb	Weight	Finish
BUBFH60BDP	Ø60xH.40 cm	3x E27	5,0 kg	bronze dark patina finish
BUBFH60GSF	Ø60xH.40 cm	3x E27	5,0 kg	gold satin finish

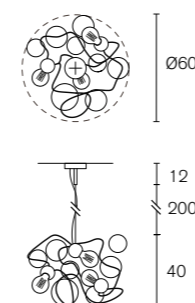

Ceiling Lamp

Art.nr.	Dimensions	Light bulb	Weight	Finish
BUBFP65BDP	Ø65xH.35 cm	3x E27	6,0 kg	bronze dark patina finish
BUBFP65GSF	Ø65xH.35 cm	3x E27	6,0 kg	gold satin finish
BUBFP90BDP	Ø90xH.35 cm	5x E27	10,0 kg	bronze dark patina finish
BUBFP90GSF	Ø90xH.35 cm	5x E27	10,0 kg	gold satin finish

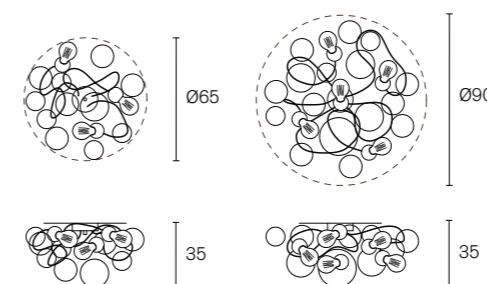

All Hanging Lamps are supplied with 2 meter steel cable, 2 meter electrical cable and a ceiling cover.
Standard glass spheres for the Bubbles Flow are iridescent (major) mixed with clear.

Collection Bubbles Flow

Hanging Lamp Long

Art.nr.	Dimensions	Light bulb	Weight	Finish
BUBFHL120BDP	L.120xW.45xH.45 cm	3x E27	9,0 kg	bronze dark patina finish
BUBFHL120GSF	L.120xW.45xH.45 cm	3x E27	9,0 kg	gold satin finish
BUBFHL140BDP	L.140xW.45xH.45 cm	4x E27	9,5 kg	bronze dark patina finish
BUBFHL140GSF	L.140xW.45xH.45 cm	4x E27	9,5 kg	gold satin finish
BUBFHL160BDP	L.160xW.45xH.45 cm	4x E27	10,0 kg	bronze dark patina finish
BUBFHL160GSF	L.160xW.45xH.45 cm	4x E27	10,0 kg	gold satin finish
BUBFHL200BDP	L.200xW.45xH.45 cm	5x E27	12,0 kg	bronze dark patina finish
BUBFHL200GSF	L.200xW.45xH.45 cm	5x E27	12,0 kg	gold satin finish

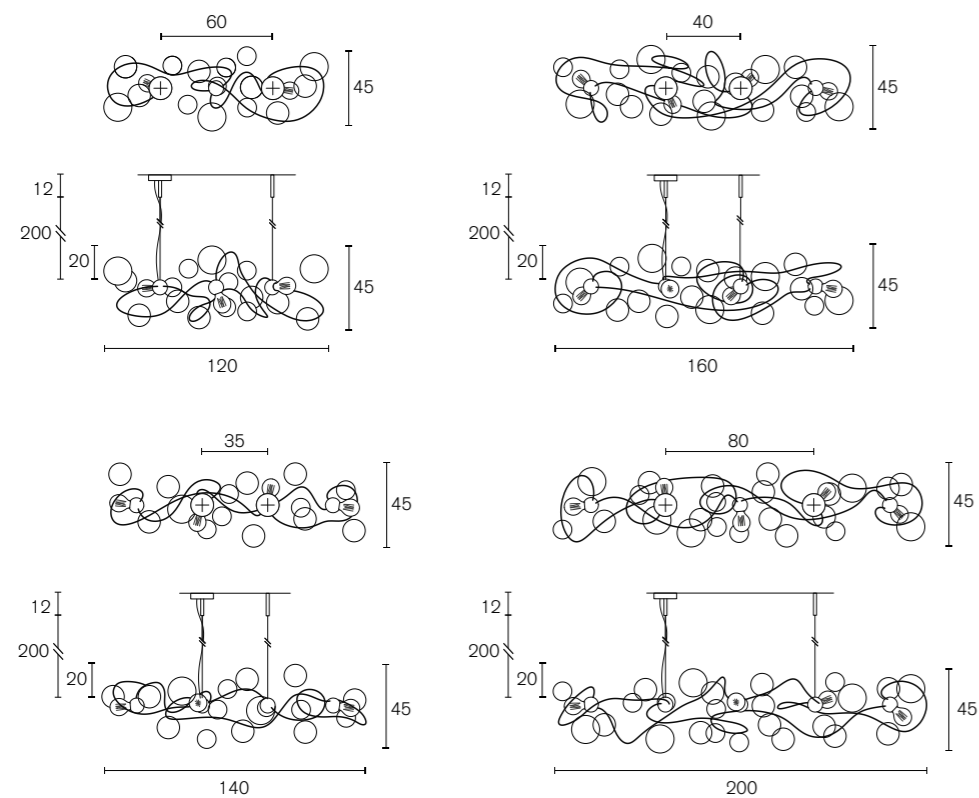

All Hanging Lamps Long are supplied with 2 meter steel cables, 2 meter electrical cable and a ceiling cover.
Standard glass spheres for the Bubbles Flow are iridescent (major) mixed with clear.

Collection Bubbles Swirl

Sculptural Object

Art.nr.	Dimensions	Light bulb	Weight	Finish
BUBSOBJ100BDP	W.100xD.80xH.100 cm	3x E27	11,0 kg	bronze dark patina finish
BUBSOBJ100GSF	W.100xD.80xH.100 cm	3x E27	11,0 kg	gold satin finish
BUBSOBJ130BDP	W.130xD.100xH.150 cm	5x E27	16,0 kg	bronze dark patina finish
BUBSOBJ130GSF	W.130xD.100xH.150 cm	5x E27	16,0 kg	gold satin finish
BUBSOBJ160BDP	W.160xD.120xH.190 cm	7x E27	23,0 kg	bronze dark patina finish
BUBSOBJ160GSF	W.160xD.120xH.190 cm	7x E27	23,0 kg	gold satin finish

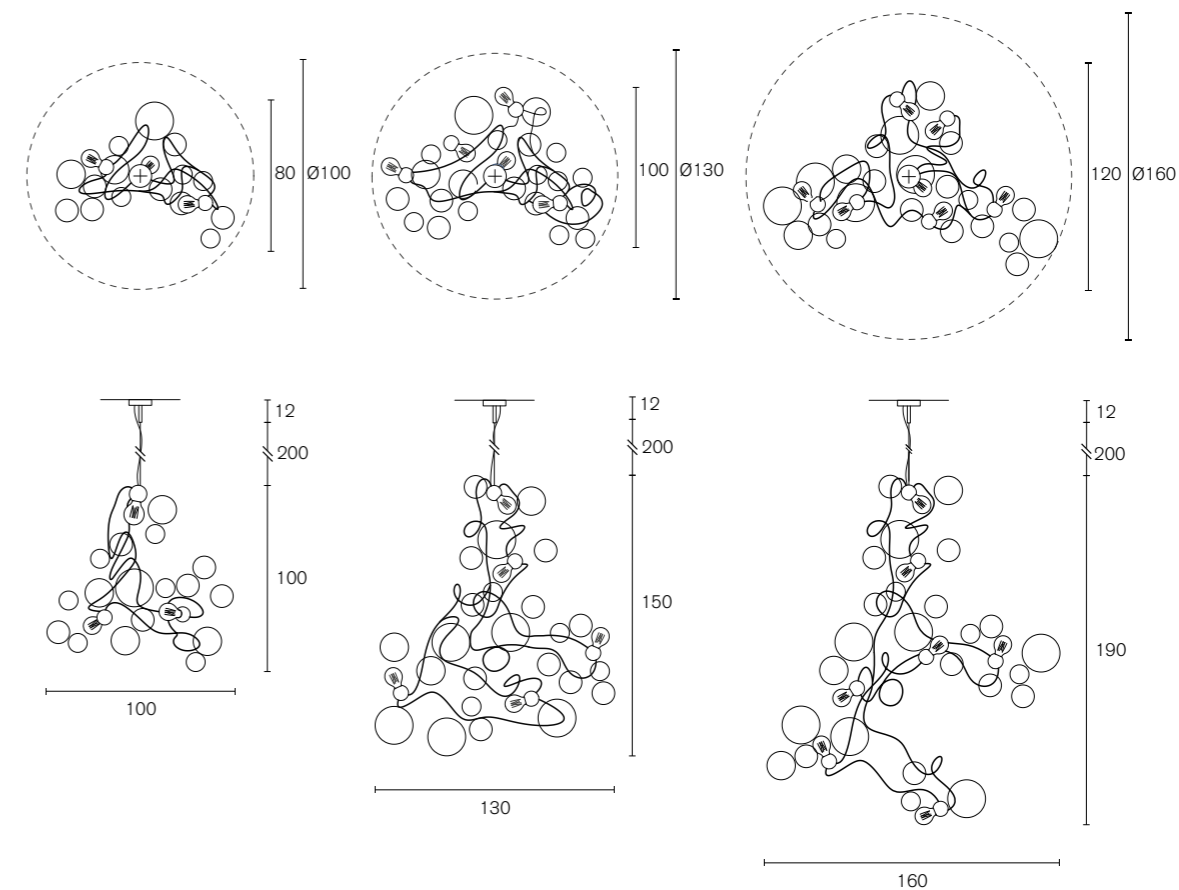

All Sculptural Objects are supplied with 2 meter steel cable, 2 meter electrical cable and a ceiling cover.
For Compositions of multiple Objects customised ceiling covers can be offered.
Standard glass spheres for the Bubbles Swirl are iridescent (major) mixed with clear.

Collection Bubbles Swirl

Hanging Lamp

Art.nr.	Dimensions	Light bulb	Weight	Finish
BUBSH40BDP	W.40xD.35xH.35 cm	1x E27	2,0 kg	bronze dark patina finish
BUBSH40GSF	W.40xD.35xH.35 cm	1x E27	2,0 kg	gold satin finish
BUBSH50BDP	W.50xD.40xH.50 cm	1x E27	3,0 kg	bronze dark patina finish
BUBSH50GSF	W.50xD.40xH.50 cm	1x E27	3,0 kg	gold satin finish

BUBSH40

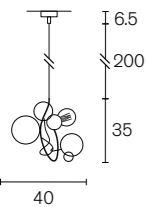

BUBSH50

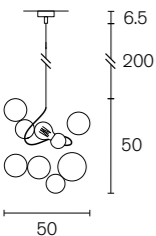
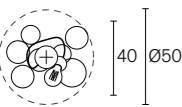

The Bubbles Swirl collection contains various elements that give a possibility to merge different objects into compositions. Number of elements, total drop, and total volume of compositions can be customised. Several measurements change with number and size of chosen Elements.

Standard the compositions will be delivered with ceiling covers in the finish of the lamps. In Line and Disc can be delivered in various finishes on request.

Suspension options

In Line IL1-3E-100 (120)

Composition
x3 Elements

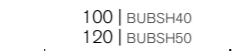
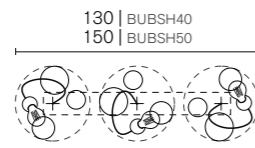

In Line IL1-5E-190 (230)

Composition
x5 Elements

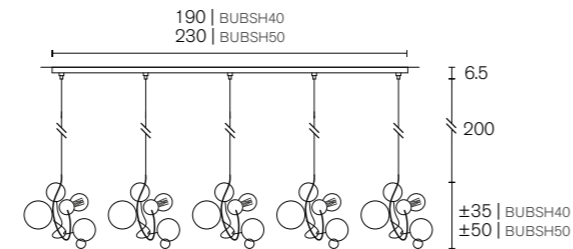
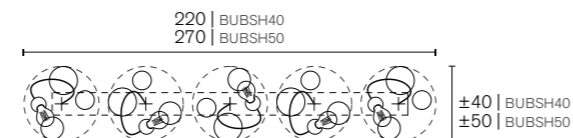

Disc CD1-3E-50 (60)

Composition
x3 Elements

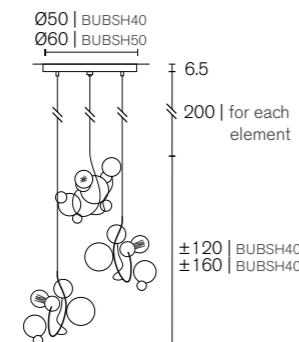
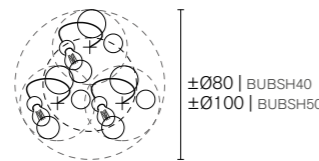

Disc CD1-5E-60

Composition
x5 Elements

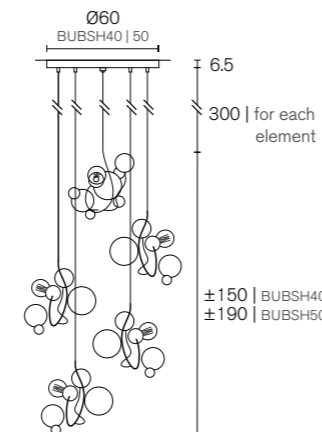
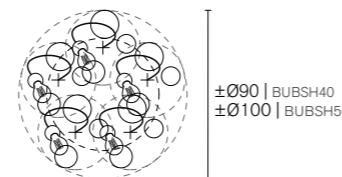

All Hanging Lamps are supplied with 2 meter electrical cable and a ceiling cover.
For Compositions of multiple Hanging Lamps customised ceiling covers can be offered.
Standard glass spheres for the Bubbles Swirl are iridescent (major) mixed with clear.

Collection Solis

Chandelier Conical

Art.nr.	Dimensions	Light bulb	Weight	Finish
SOLCC70BLM	Ø70xH.80 cm	12x E14	21,0 kg	black matt finish
SOLCC70BLM-BDP	Ø70xH.80 cm	12x E14	21,0 kg	black matt finish with bronze dark patina finish finish reflectors
SOLCC70BLM-ST	Ø70xH.80 cm	12x E14	21,0 kg	black matt finish with stainless steel reflectors
SOLCC70BLM-BRBRUR	Ø70xH.80 cm	12x E14	21,0 kg	black matt finish with brass burnished reflectors
SOLCC70BLM-GSF	Ø70xH.80 cm	12x E14	21,0 kg	black matt finish with gold satin reflectors
SOLCC70BDP-BLM	Ø70xH.80 cm	12x E14	21,0 kg	bronze dark patina finish with black matt reflectors
SOLCC70BDP	Ø70xH.80 cm	12x E14	21,0 kg	bronze dark patina finish
SOLCC70BDP-ST	Ø70xH.80 cm	12x E14	21,0 kg	bronze dark patina finish with stainless steel reflectors
SOLCC70BDP-BRBRUR	Ø70xH.80 cm	12x E14	21,0 kg	bronze dark patina finish with brass burnished reflectors
SOLCC70BDP-GSF	Ø70xH.80 cm	12x E14	21,0 kg	bronze dark patina finish with gold satin reflectors

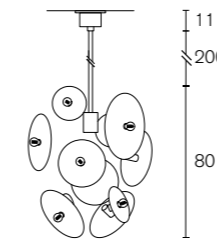

Chandelier Oval

Art.nr.	Dimensions	Light bulb	Weight	Finish
SOLOC120BLM	L.120xW.70xH.50 cm	12x E14	20,0 kg	black matt finish
SOLOC120BLM-BDP	L.120xW.70xH.50 cm	12x E14	20,0 kg	black matt finish with bronze dark patina finish reflectors
SOLOC120BLM-ST	L.120xW.70xH.50 cm	12x E14	20,0 kg	black matt finish with stainless steel reflectors
SOLOC120BLM-BRBRUR	L.120xW.70xH.50 cm	12x E14	20,0 kg	black matt finish with brass burnished reflectors
SOLOC120BLM-GSF	L.120xW.70xH.50 cm	12x E14	20,0 kg	black matt finish with gold satin reflectors
SOLOC120BDP-BLM	L.120xW.70xH.50 cm	12x E14	20,0 kg	bronze dark patina finish with black matt reflectors
SOLOC120BDP	L.120xW.70xH.50 cm	12x E14	20,0 kg	bronze dark patina finish
SOLOC120BDP-ST	L.120xW.70xH.50 cm	12x E14	20,0 kg	bronze dark patina finish with stainless steel reflectors
SOLOC120BDP-BRBRUR	L.120xW.70xH.50 cm	12x E14	20,0 kg	bronze dark patina finish with brass burnished reflectors
SOLOC120BDP-GSF	L.120xW.70xH.50 cm	12x E14	20,0 kg	bronze dark patina finish with gold satin reflectors

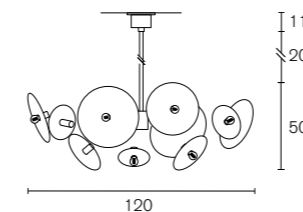
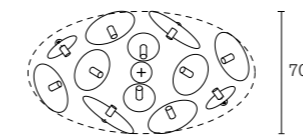

All Chandeliers are supplied with 2 meter stem and a ceiling cover.

Collection Solis

Chandelier Round

Art.nr.	Dimensions	Light bulb	Weight	Finish
SOLC100BLM	Ø100xH.55 cm	12x E14	22,0 kg	black matt finish
SOLC100BLM-BDP	Ø100xH.55 cm	12x E14	22,0 kg	black matt finish with bronze dark patina finish reflectors
SOLC100BLM-ST	Ø100xH.55 cm	12x E14	22,0 kg	black matt finish with stainless steel reflectors
SOLC100BLM-BR BUR	Ø100xH.55 cm	12x E14	22,0 kg	black matt finish with brass burnished reflectors
SOLC100BLM-GSF	Ø100xH.55 cm	12x E14	22,0 kg	black matt finish with gold satin reflectors
SOLC100BDP-BLM	Ø100xH.55 cm	12x E14	22,0 kg	bronze dark patina finish with black matt reflectors
SOLC100BDP	Ø100xH.55 cm	12x E14	22,0 kg	bronze dark patina finish
SOLC100BDP-ST	Ø100xH.55 cm	12x E14	22,0 kg	bronze dark patina finish with stainless steel reflectors
SOLC100BDP-BR BUR	Ø100xH.55 cm	12x E14	22,0 kg	bronze dark patina finish with brass burnished reflectors
SOLC100BDP-GSF	Ø100xH.55 cm	12x E14	22,0 kg	bronze dark patina finish with gold satin reflectors

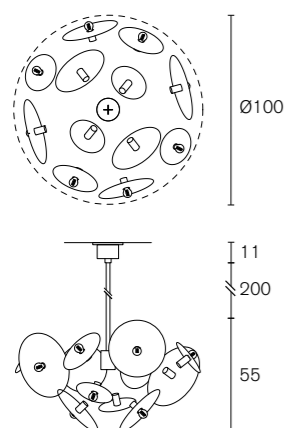

All Chandeliers are supplied with 2 meter stem and a ceiling cover.

Collection Solis

Hanging Lamp

Art.nr.	Dimensions	Light bulb	Weight	Finish
SOLH40BLM	Ø40xH.30 cm	5x E14	5,0 kg	black matt finish
SOLH40BLM-BDP	Ø40xH.30 cm	5x E14	5,0 kg	black matt finish with bronze dark patina finish reflectors
SOLH40BLM-ST	Ø40xH.30 cm	5x E14	5,0 kg	black matt finish with stainless steel reflectors
SOLH40BLM-BR BUR	Ø40xH.30 cm	5x E14	5,0 kg	black matt finish with brass burnished reflectors
SOLH40BLM-GSF	Ø40xH.30 cm	5x E14	5,0 kg	black matt finish with gold satin reflectors
SOLH40BDP-BLM	Ø40xH.30 cm	5x E14	5,0 kg	bronze dark patina finish with black matt reflectors
SOLH40BDP	Ø40xH.30 cm	5x E14	5,0 kg	bronze dark patina finish
SOLH40BDP-ST	Ø40xH.30 cm	5x E14	5,0 kg	bronze dark patina finish with stainless steel reflectors
SOLH40BDP-BR BUR	Ø40xH.30 cm	5x E14	5,0 kg	bronze dark patina finish with brass burnished reflectors
SOLH40BDP-GSF	Ø40xH.30 cm	5x E14	5,0 kg	bronze dark patina finish with gold satin reflectors
SOLH55BLM	Ø55xH.40 cm	5x E14	7,0 kg	black matt finish
SOLH55BLM-BDP	Ø55xH.40 cm	5x E14	7,0 kg	black matt finish with bronze dark patina finish reflectors
SOLH55BLM-ST	Ø55xH.40 cm	5x E14	7,0 kg	black matt finish with stainless steel reflectors
SOLH55BLM-BR BUR	Ø55xH.40 cm	5x E14	7,0 kg	black matt finish with brass burnished reflectors
SOLH55BLM-GSF	Ø55xH.40 cm	5x E14	7,0 kg	black matt finish with gold satin reflectors
SOLH55BDP-BLM	Ø55xH.40 cm	5x E14	7,0 kg	bronze dark patina finish with black matt reflectors
SOLH55BDP	Ø55xH.40 cm	5x E14	7,0 kg	bronze dark patina finish
SOLH55BDP-ST	Ø55xH.40 cm	5x E14	7,0 kg	bronze dark patina finish with stainless steel reflectors
SOLH55BDP-BR BUR	Ø55xH.40 cm	5x E14	7,0 kg	bronze dark patina finish with brass burnished reflectors
SOLH55BDP-GSF	Ø55xH.40 cm	5x E14	7,0 kg	bronze dark patina finish with gold satin reflectors
SOLH65BLM	Ø65xH.40 cm	6x E14	10,0 kg	black matt finish
SOLH65BLM-BDP	Ø65xH.40 cm	6x E14	10,0 kg	black matt finish with bronze dark patina finish reflectors
SOLH65BLM-ST	Ø65xH.40 cm	6x E14	10,0 kg	black matt finish with stainless steel reflectors
SOLH65BLM-BR BUR	Ø65xH.40 cm	6x E14	10,0 kg	black matt finish with brass burnished reflectors
SOLH65BLM-GSF	Ø65xH.40 cm	6x E14	10,0 kg	black matt finish with gold satin reflectors
SOLH65BDP-BLM	Ø65xH.40 cm	6x E14	10,0 kg	bronze dark patina finish with black matt reflectors
SOLH65BDP	Ø65xH.40 cm	6x E14	10,0 kg	bronze dark patina finish
SOLH65BDP-ST	Ø65xH.40 cm	6x E14	10,0 kg	bronze dark patina finish with stainless steel reflectors
SOLH65BDP-BR BUR	Ø65xH.40 cm	6x E14	10,0 kg	bronze dark patina finish with brass burnished reflectors
SOLH65BDP-GSF	Ø65xH.40 cm	6x E14	10,0 kg	bronze dark patina finish with gold satin reflectors

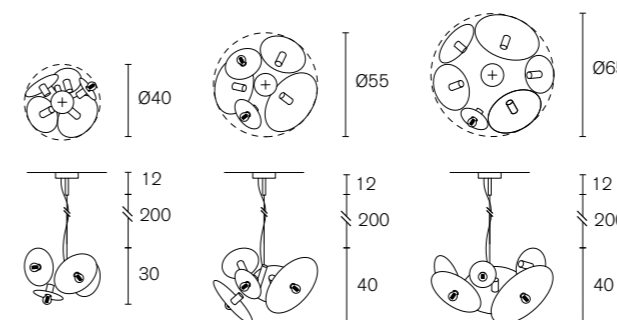

All Hanging Lamps are supplied with 2 meter steel cable, 2 meter electrical cable and a ceiling cover.

Collection Solis

Hanging Lamp Long

Art.nr.	Dimensions	Light bulb	Weight	Finish
SOLHL125BLM	L.125xW.45xH.40 cm	12x E14	15,5 kg	black matt finish
SOLHL125BLM-BDP	L.125xW.45xH.40 cm	12x E14	15,5 kg	black matt finish with bronze dark patina finish reflectors
SOLHL125BLM-ST	L.125xW.45xH.40 cm	12x E14	15,5 kg	black matt finish with stainless steel reflectors
SOLHL125BLM-BR BUR	L.125xW.45xH.40 cm	12x E14	15,5 kg	black matt finish with brass burnished reflectors
SOLHL125BLM-GSF	L.125xW.45xH.40 cm	12x E14	15,5 kg	black matt finish with gold satin reflectors
SOLHL125BDP-BLM	L.125xW.45xH.40 cm	12x E14	15,5 kg	bronze dark patina finish with black matt reflectors
SOLHL125BDP	L.125xW.45xH.40 cm	12x E14	15,5 kg	bronze dark patina finish
SOLHL125BDP-ST	L.125xW.45xH.40 cm	12x E14	15,5 kg	bronze dark patina finish with stainless steel reflectors
SOLHL125BDP-BR BUR	L.125xW.45xH.40 cm	12x E14	15,5 kg	bronze dark patina finish with brass burnished reflectors
SOLHL125BDP-GSF	L.125xW.45xH.40 cm	12x E14	15,5 kg	bronze dark patina finish with gold satin reflectors

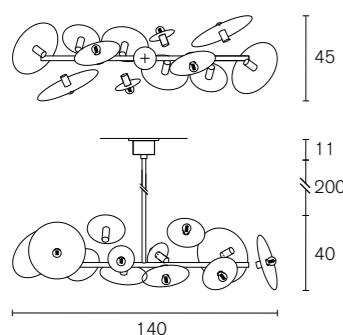

Hanging Lamp Vertical

Art.nr.	Dimensions	Light bulb	Weight	Finish
SOLV150BLM	Ø50xH.150 cm	14x E14	17 kg	black matt finish
SOLV150BLM-BDP	Ø50xH.150 cm	14x E14	17 kg	black matt finish with bronze dark patina finish reflectors
SOLV150BLM-ST	Ø50xH.150 cm	14x E14	17 kg	black matt finish with stainless steel reflectors
SOLV150BLM-BR BUR	Ø50xH.150 cm	14x E14	17 kg	black matt finish with brass burnished reflectors
SOLV150BLM-GSF	Ø50xH.150 cm	14x E14	17 kg	black matt finish with gold satin reflectors
SOLV150BDP-BLM	Ø50xH.150 cm	14x E14	17 kg	bronze dark patina finish with black matt reflectors
SOLV150BDP	Ø50xH.150 cm	14x E14	17 kg	bronze dark patina finish
SOLV150BDP-ST	Ø50xH.150 cm	14x E14	17 kg	bronze dark patina finish with stainless steel reflectors
SOLV150BDP-BR BUR	Ø50xH.150 cm	14x E14	17 kg	bronze dark patina finish with brass burnished reflectors
SOLV150BDP-GSF	Ø50xH.150 cm	14x E14	17 kg	bronze dark patina finish with gold satin reflectors

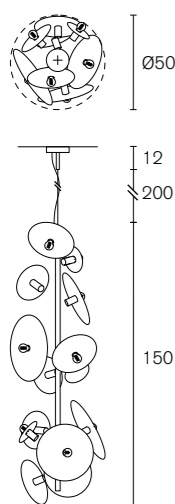

All Hanging Lamps Long are supplied with 2 meter stem and a ceiling cover.
All Hanging Lamps Vertical are supplied with 2 meter steel cable, 2 meter electrical cable and a ceiling cover.

Collection Solis

Ceiling Lamp

Art.nr.	Dimensions	Light bulb	Weight	Finish
SOLP35BLM	Ø35xH.20 cm	3x E14	5 kg	black matt finish
SOLP35BLM-BDP	Ø35xH.20 cm	3x E14	5 kg	black matt finish with bronze dark patina finish reflectors
SOLP35BLM-ST	Ø35xH.20 cm	3x E14	5 kg	black matt finish with stainless steel reflectors
SOLP35BLM-BR BUR	Ø35xH.20 cm	3x E14	5 kg	black matt finish with brass burnished reflectors
SOLP35BLM-GSF	Ø35xH.20 cm	3x E14	5 kg	black matt finish with gold satin reflectors
SOLP35BDP-BLM	Ø35xH.20 cm	3x E14	5 kg	bronze dark patina finish with black matt reflectors
SOLP35BDP	Ø35xH.20 cm	3x E14	5 kg	bronze dark patina finish
SOLP35BDP-ST	Ø35xH.20 cm	3x E14	5 kg	bronze dark patina finish with stainless steel reflectors
SOLP35BDP-BR BUR	Ø35xH.20 cm	3x E14	5 kg	bronze dark patina finish with brass burnished reflectors
SOLP35BDP-GSF	Ø35xH.20 cm	3x E14	5 kg	bronze dark patina finish with gold satin reflectors
SOLP65BLM	Ø65xH.25 cm	5x E14	8 kg	black matt finish
SOLP65BLM-BDP	Ø65xH.25 cm	5x E14	8 kg	black matt finish with bronze dark patina finish reflectors
SOLP65BLM-ST	Ø65xH.25 cm	5x E14	8 kg	black matt finish with stainless steel reflectors
SOLP65BLM-BR BUR	Ø65xH.25 cm	5x E14	8 kg	black matt finish with brass burnished reflectors
SOLP65BLM-GSF	Ø65xH.25 cm	5x E14	8 kg	black matt finish with gold satin reflectors
SOLP65BDP-BLM	Ø65xH.25 cm	5x E14	8 kg	bronze dark patina finish with black matt reflectors
SOLP65BDP	Ø65xH.25 cm	5x E14	8 kg	bronze dark patina finish
SOLP65BDP-ST	Ø65xH.25 cm	5x E14	8 kg	bronze dark patina finish with stainless steel reflectors
SOLP65BDP-BR BUR	Ø65xH.25 cm	5x E14	8 kg	bronze dark patina finish with brass burnished reflectors
SOLP65BDP-GSF	Ø65xH.25 cm	5x E14	8 kg	bronze dark patina finish with gold satin reflectors
SOLP90BLM	Ø90xH.25 cm	5x E14	10 kg	black matt finish
SOLP90BLM-BDP	Ø90xH.25 cm	5x E14	10 kg	black matt finish with bronze dark patina finish reflectors
SOLP90BLM-ST	Ø90xH.25 cm	5x E14	10 kg	black matt finish with stainless steel reflectors
SOLP90BLM-BR BUR	Ø90xH.25 cm	5x E14	10 kg	black matt finish with brass burnished reflectors
SOLP90BLM-GSF	Ø90xH.25 cm	5x E14	10 kg	black matt finish with gold satin reflectors
SOLP90BDP-BLM	Ø90xH.25 cm	5x E14	10 kg	bronze dark patina finish with black matt reflectors
SOLP90BDP	Ø90xH.25 cm	5x E14	10 kg	bronze dark patina finish
SOLP90BDP-ST	Ø90xH.25 cm	5x E14	10 kg	bronze dark patina finish with stainless steel reflectors
SOLP90BDP-BR BUR	Ø90xH.25 cm	5x E14	10 kg	bronze dark patina finish with brass burnished reflectors
SOLP90BDP-GSF	Ø90xH.25 cm	5x E14	10 kg	bronze dark patina finish with gold satin reflectors

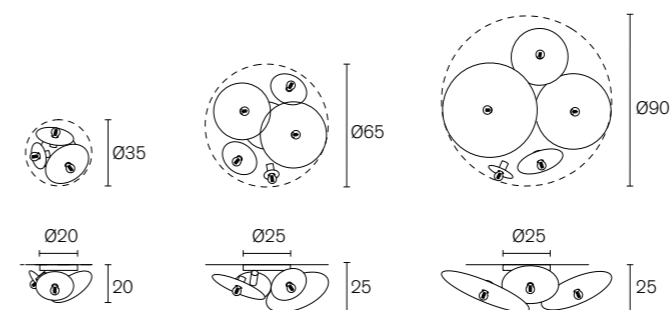

Solis Ceiling Lamps can be offered also as wall lights.

Collection Solis

Floor Lamp

Art.nr.	Dimensions	Light bulb	Weight	Finish
SOLF200BLM	Ø50xH.200 cm	7x E14	27 kg	black matt finish
SOLF200BLM-BDP	Ø50xH.200 cm	7x E14	27 kg	black matt finish with bronze dark patina finish reflectors
SOLF200BLM-ST	Ø50xH.200 cm	7x E14	27 kg	black matt finish with stainless steel reflectors
SOLF200BLM-BRBRUR	Ø50xH.200 cm	7x E14	27 kg	black matt finish with brass burnished reflectors
SOLF200BLM-GSF	Ø50xH.200 cm	7x E14	27 kg	black matt finish with gold satin reflectors
SOLF200BDP-BLM	Ø50xH.200 cm	7x E14	27 kg	bronze dark patina finish with black matt reflectors
SOLF200BDP	Ø50xH.200 cm	7x E14	27 kg	bronze dark patina finish
SOLF200BDP-ST	Ø50xH.200 cm	7x E14	27 kg	bronze dark patina finish with stainless steel reflectors
SOLF200BDP-BRBRUR	Ø50xH.200 cm	7x E14	27 kg	bronze dark patina finish with brass burnished reflectors
SOLF200BDP-GSF	Ø50xH.200 cm	7x E14	27 kg	bronze dark patina finish with gold satin reflectors

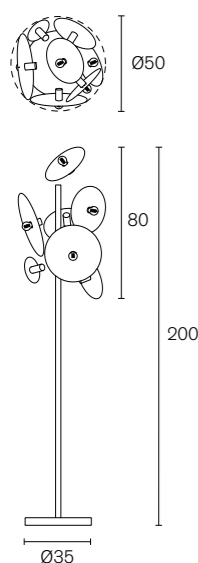

All Floor Lamps are supplied with a floor dimmer.

If ordered in brass burnished or copper burnished finish lamps will be coated with a protective nano wax.

Collection Solis

Table Lamp

Art.nr.	Dimensions	Light bulb	Weight	Finish
SOLT75BLM	Ø40xH.75 cm	5x E14	10 kg	black matt finish
SOLT75BLM-BDP	Ø40xH.75 cm	5x E14	10 kg	black matt finish with bronze dark patina finish reflectors
SOLT75BLM-ST	Ø40xH.75 cm	5x E14	10 kg	black matt finish with stainless steel reflectors
SOLT75BLM-BRBRUR	Ø40xH.75 cm	5x E14	10 kg	black matt finish with brass burnished reflectors
SOLT75BLM-GSF	Ø40xH.75 cm	5x E14	10 kg	black matt finish with gold satin reflectors
SOLT75BDP-BLM	Ø40xH.75 cm	5x E14	10 kg	bronze dark patina finish with black matt reflectors
SOLT75BDP	Ø40xH.75 cm	5x E14	10 kg	bronze dark patina finish
SOLT75BDP-ST	Ø40xH.75 cm	5x E14	10 kg	bronze dark patina finish with stainless steel reflectors
SOLT75BDP-BRBRUR	Ø40xH.75 cm	5x E14	10 kg	bronze dark patina finish with brass burnished reflectors
SOLT75BDP-GSF	Ø40xH.75 cm	5x E14	10 kg	bronze dark patina finish with gold satin reflectors

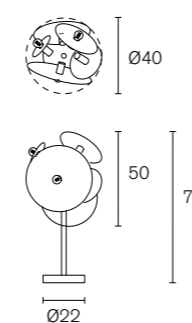

All table lamps are supplied with a dimmer.

If ordered in brass burnished or copper burnished finish lamps will be coated with a protective nano wax.

Wall Lamp

Art.nr.	Dimensions	Light bulb	Weight	Finish
SOLW35BLM	Ø35xH.20 cm	3x E14	5 kg	black matt finish
SOLW35BLM-BDP	Ø35xH.20 cm	3x E14	5 kg	black matt finish with bronze dark patina finish reflectors
SOLW35BLM-ST	Ø35xH.20 cm	3x E14	5 kg	black matt finish with stainless steel reflectors
SOLW35BLM-BRBRUR	Ø35xH.20 cm	3x E14	5 kg	black matt finish with brass burnished reflectors
SOLW35BLM-GSF	Ø35xH.20 cm	3x E14	5 kg	black matt finish with gold satin reflectors
SOLW35BDP-BLM	Ø35xH.20 cm	3x E14	5 kg	bronze dark patina finish with black matt reflectors
SOLW35BDP	Ø35xH.20 cm	3x E14	5 kg	bronze dark patina finish
SOLW35BDP-ST	Ø35xH.20 cm	3x E14	5 kg	bronze dark patina finish with stainless steel reflectors
SOLW35BDP-BRBRUR	Ø35xH.20 cm	3x E14	5 kg	bronze dark patina finish with brass burnished reflectors
SOLW35BDP-GSF	Ø35xH.20 cm	3x E14	5 kg	bronze dark patina finish with gold satin reflectors

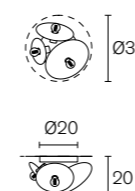

Collection Primavera

Chandelier

Art.nr.	Dimensions	Light bulb	Weight	Finish
PRIC60BLM	Ø60xH.92 cm	6x G9	13,5 kg	black matt finish
PRIC60WM	Ø60xH.92 cm	6x G9	13,5 kg	white matt finish
PRIC60BDP	Ø60xH.92 cm	6x G9	13,5 kg	bronze dark patina finish
PRIC60BRBUR	Ø60xH.92 cm	6x G9	13,5 kg	brass burnished finish
PRIC60GSF	Ø60xH.92 cm	6x G9	13,5 kg	gold satin finish
PRIC90BLM	Ø90xH.107 cm	12x G9	25,0 kg	black matt finish
PRIC90WM	Ø90xH.107 cm	12x G9	25,0 kg	white matt finish
PRIC90BDP	Ø90xH.107 cm	12x G9	25,0 kg	bronze dark patina finish
PRIC90BRBUR	Ø90xH.107 cm	12x G9	25,0 kg	brass burnished finish
PRIC90GSF	Ø90xH.107 cm	12x G9	25,0 kg	gold satin finish

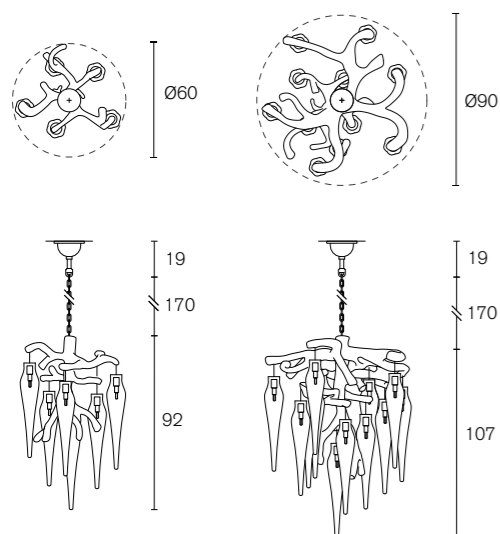

Wall

Art.nr.	Dimensions	Light bulb	Weight	Finish
PRIW50BLM	W.10xH.52xD.17 cm	1x G9	4,0 kg	black matt finish
PRIW50WM	W.10xH.52xD.17 cm	1x G9	4,0 kg	white matt finish
PRIW50BDP	W.10xH.52xD.17 cm	1x G9	4,0 kg	bronze dark patina finish
PRIW50BRBUR	W.10xH.52xD.17 cm	1x G9	4,0 kg	brass burnished finish
PRIW50GSF	W.10xH.52xD.17 cm	1x G9	4,0 kg	gold satin finish

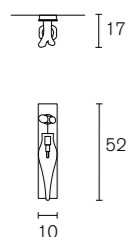

All Chandeliers are supplied with 1,7 meter chain, 2 meter electrical cable and a ceiling cover.
All elements are supplied with 2 meter electrical cable and a ceiling cover.
For Compositions of multiple Elements customised ceiling covers can be offered.

Collection Primavera

Element

Art.nr.	Dimensions	Light bulb	Weight	Finish
PRI30BLM	Ø30xH.80 cm	3x G9	4,5 kg	black matt finish
PRI30WM	Ø30xH.80 cm	3x G9	4,5 kg	white matt finish
PRI30BDP	Ø30xH.80 cm	3x G9	4,5 kg	bronze dark patina finish
PRI30BRBUR	Ø30xH.80 cm	3x G9	4,5 kg	brass burnished finish
PRI30GSF	Ø30xH.80 cm	3x G9	4,5 kg	gold satin finish

PRI30

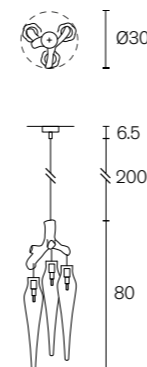

Suspension options

In Line IL1-3E-100

Composition
x3 Elements

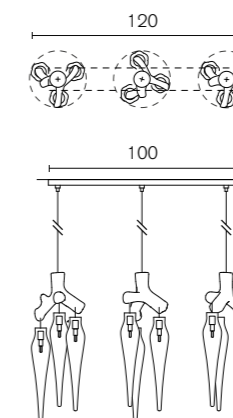

In Line IL-5E-190

Composition
x5 Elements

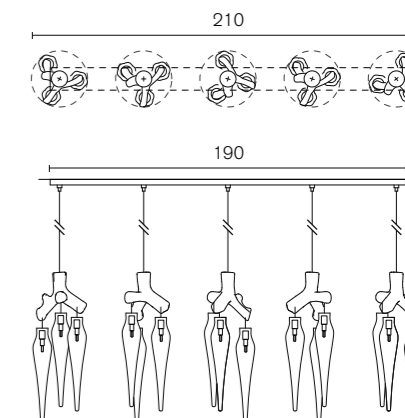

Disc CD1-3E-50

Composition
x3 Elements

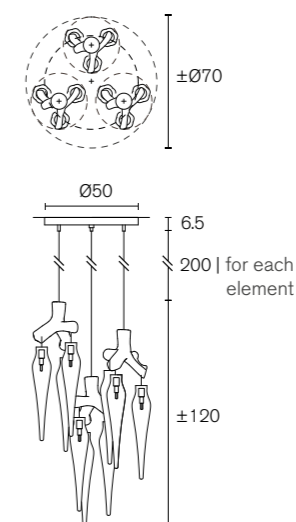

Disc CD1-5E-60

Composition
x5 Elements

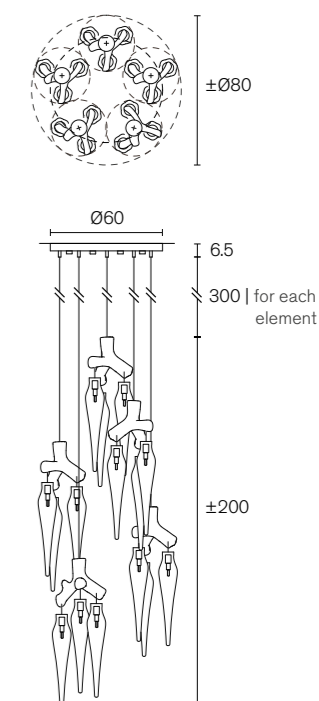

The Primavera collection contains various elements that give a possibility to merge different objects into compositions. Number of elements, total drop, and total volume of compositions can be customised. Several measurements change with number and size of chosen Elements.

Standard the compositions will be delivered with ceiling covers in the finish of the lamps. The ceiling covers In Line and Disc can be delivered in various finishes on request.

All elements are supplied with 2 meter steel cable, 2 meter electrical cable and a ceiling cover.
For Compositions of multiple Elements customised ceiling covers can be offered.

Collection Primavera Icicles

Element

Art.nr.	Dimensions	Light bulb	Weight	Finish
PRISI35N	Ø10xH.35 cm	1x G9	1 kg	nickel finish
PRISI50N	Ø10xH.50 cm	1x G9	1 kg	nickel finish

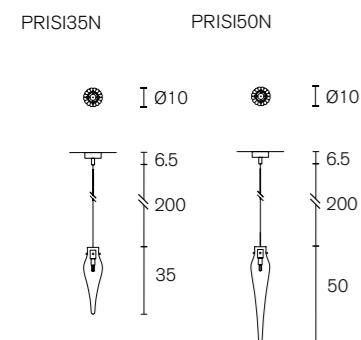

In Line IL4-15E-140

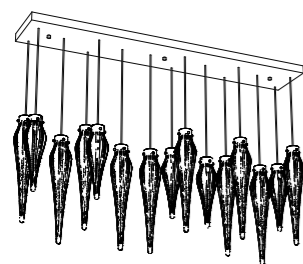

Disc CD4-15E-60



Suspension options

The Primavera Icicles Elements give a possibility to merge it into various compositions. Number of elements, total drop, and total volume of compositions can be customised. Several measurements change with number and size of chosen Elements.

Standard the Primavera Icicles compositions will be delivered with polished stainless steel ceiling covers. The ceiling covers In Line and Disc can be delivered in various finishes on request.

In Line IL4-15E-140

Composition of mixed elements
PRISI35N | PRISI50N
x15 Elements

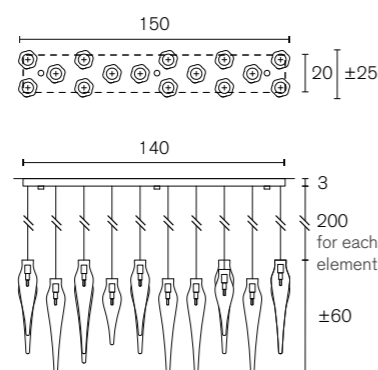

In Line IL4-21E-200

Composition of mixed elements
PRISI35N | PRISI50N
x21 Elements

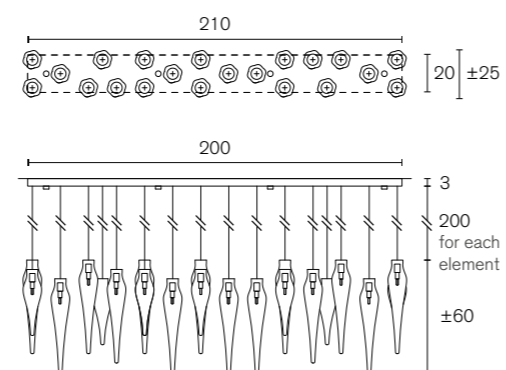

Disc CD4-19E-60

Composition of mixed elements
PRISI35N | PRISI50N
x19 Elements

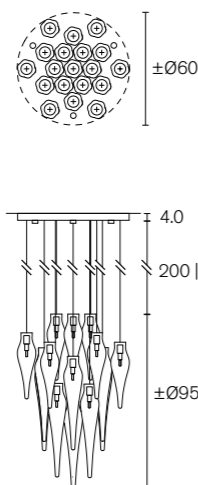

Disc CD4-31E-80

Composition of mixed elements
PRISI35N | PRISI50N
x31 Elements

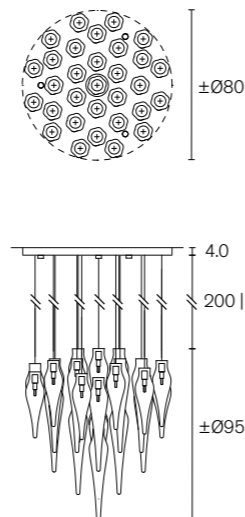

All Elements are supplied with 2 meter steel cable, 2 meter electrical cable and a ceiling cover.
For Compositions of multiple Elements customised ceiling covers can be offered.

Collection Desert Wind

Chandelier Conical

Art.nr.	Dimensions	Light bulb	Weight	Finish
DEWCC80BLM	Ø80xH.80 cm	9x E14	22 kg	black matt finish
DEWCC80GSF	Ø80xH.80 cm	9x E14	22 kg	gold satin finish

Chandelier Oval

Art.nr.	Dimensions	Light bulb	Weight	Finish
DEWOC140BLM	L.140xW.65xH.55 cm	10x E14	27 kg	black matt finish
DEWOC140GSF	L.140xW.65xH.55 cm	10x E14	27 kg	gold satin finish

Chandelier Round

Art.nr.	Dimensions	Light bulb	Weight	Finish
DEWC125BLM	Ø125xH.55 cm	11x E14	25 kg	black matt finish
DEWC125GSF	Ø125xH.55 cm	11x E14	25 kg	gold satin finish

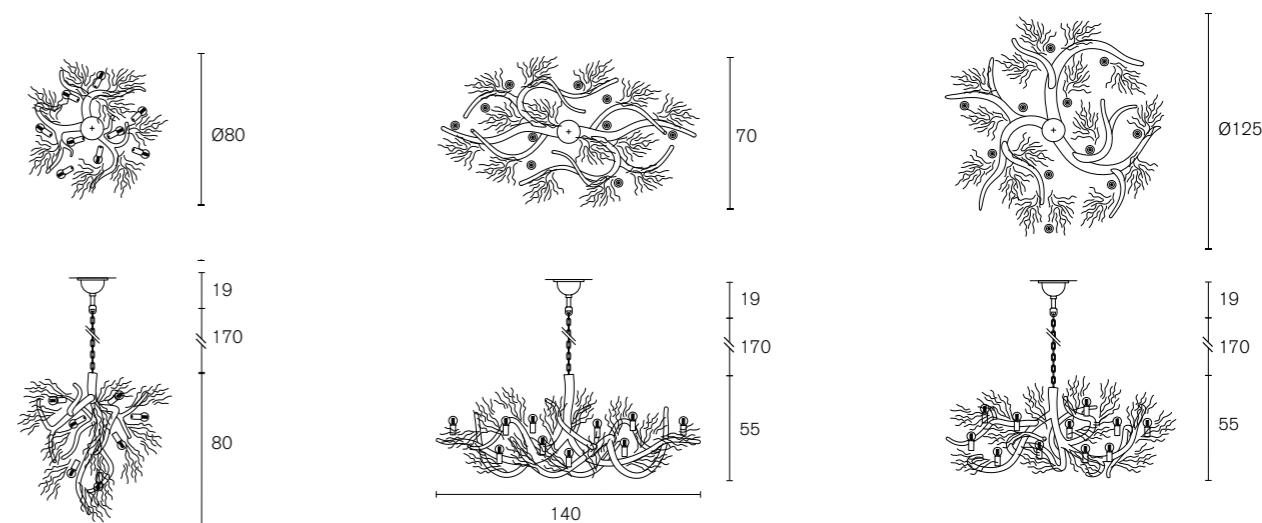

All Chandeliers are supplied with 1,7 meter chain, 2 meter electrical cable and a ceiling cover.

Collection Takara

Hanging Lamp Long

Art.nr.	Dimensions	Light bulb	Weight	Finish
TAKHL150BDP	L.142xW.12xH.14 cm	2x LED STRIPE L. 100CM	21 kg	cast bronze dark patina
TAKHL200BDP	L.194xW.18xH.14 cm	2x LED STRIPE L. 150CM	27 kg	cast bronze dark patina

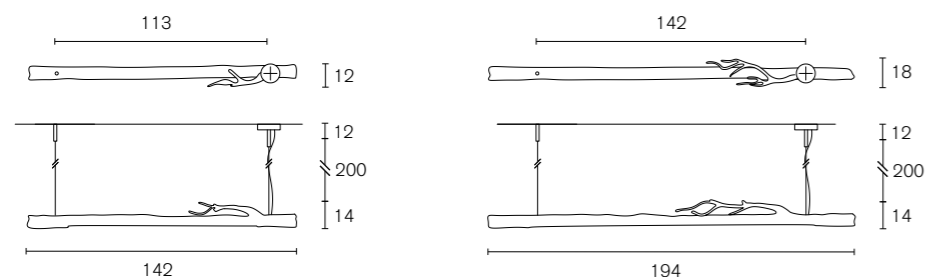

Certificate



Each BRAND VAN EGMOND lighting sculpture is issued with a certificate of authenticity and registered with a unique number. This guarantees that you are in possession of an original BRAND VAN EGMOND object.

We advise you to keep this certificate together with your receipt of purchase in a safe place.

All Hanging Lamps Long are supplied with 2 meter steel cable, 2 meter electrical cable and a ceiling cover.

General Terms and Conditions of Sales

1. Applicability of terms and Conditions of Sales

- 1.1 These general conditions of sales and delivery shall apply to all offers, quotes, deliveries, services and agreements of Brand van Egmond B.V. ("BRAND VAN EGMOND").
- 1.2 All orders are accepted and executed by BRAND VAN EGMOND subject to and in accordance with the following conditions of sales which override and exclude any other terms stipulated or incorporated or referred to by the customer during any negotiations or in any course of dealing between BRAND VAN EGMOND and the customer.
- 1.3 No variation or deviation to these conditions of sales is permitted unless expressly authorised in writing by a director of BRAND VAN EGMOND.

2. Quotations and orders

- 2.1 Subject to the terms contained in this section, any quotation provided by BRAND VAN EGMOND will be without engagement.
- 2.2 Although BRAND VAN EGMOND strives to provide accurate product and pricing information, errors or misprints may occur. BRAND VAN EGMOND cannot confirm the price of a product until after the customer orders the product. Notwithstanding anything contained in this section, in the event that a product is listed at an incorrect price or with incorrect information due to an error in pricing or product information, BRAND VAN EGMOND shall have the right, at its sole discretion, to refuse or cancel any orders placed for that product. In the event that a product is priced in error or a product information error occurs, BRAND VAN EGMOND may, at its sole discretion, either contact the customer for instructions, cancel the order and notify the customer of such cancellation, and/or correct the error on its web site/pricelist, any without liability.
- 2.3 Orders are not binding on BRAND VAN EGMOND until accepted by BRAND VAN EGMOND. BRAND VAN EGMOND's acceptance of an order is evidenced in writing including return e-mail from BRAND VAN EGMOND indicating that customer's order has been accepted.
- 2.4 Changes of orders will be accepted up to 3 (three) days only from our order confirmation.
- 2.5 The cancellation of a confirmed order is valid only if it is accepted in writing by BRAND VAN EGMOND. Expenses due to cancellation will be charged.

3. Prices

- 3.1 Prices for products are in EUR and exclusive of VAT, unless otherwise indicated.
- 3.2 BRAND VAN EGMOND reserves the right to increase prices after execution of the agreement and without notice at any time in the event that the manufacturing prices of BRAND VAN EGMOND increase.
- 3.3 Unless indicated otherwise in writing by BRAND VAN EGMOND, the prices are based on delivery on the basis of EXW (Ex Works), Naarden, The Netherlands (according to the latest version of the ICC Incoterms®).

4. Payment

- 4.1 Unless credit terms have been agreed to in writing by BRAND VAN EGMOND, customer shall pay invoices within thirty (30) days from the date of the invoices without any deductions or set-off whatsoever.
- 4.2 If payment is not received by BRAND VAN EGMOND by the due date, the customer shall pay a financing charge of 2% of the capital sum for each month or portion thereof during which payment remains outstanding, until payment is made in full.
- 4.3 BRAND VAN EGMOND reserves the right to demand payment up front or to demand security for the payment of the invoices before commencing the production and/or delivery of the products.
- 4.4 If the customer fails to make payment by the due date or fails to provide security without prejudice to any other right or remedy, and without prior notice of default, BRAND VAN EGMOND shall be entitled to: i. cancel the order or suspend any further deliveries; and ii. appropriate any payment made by the customer to such of the products (or the products supplied under any other contract) as BRAND VAN EGMOND may think fit.
- 4.5 All expenses in connection with the recovery of the amounts payable and not paid in time by BRAND VAN EGMOND shall be for the account of the customer. The extrajudicial expenses shall be at least 15% of the amount due, at a minimum of Euro 750, and shall already be payable and claimable as soon as the claim is passed out of hand for collection.

5. Accounts

A customer wishing to open a credit account must furnish such information as requested by BRAND VAN EGMOND and BRAND VAN EGMOND will make a search with a credit reference agency. BRAND VAN EGMOND reserves the right in its absolute discretion to grant, refuse or discontinue any credit facilities or reduce or suspend any credit limit at any time.

6. Product availability; special orders

- 6.1 Product availability may be limited. Products may not be available for immediate delivery. BRAND VAN EGMOND reserves the right, without liability or prior notice, to revise or cease to make available any or all products. All articles shall be executed in standard design.
- 6.2 For an order of deviating models or colours or special requests a surcharge shall be made, this after prior written consultation. All special orders are, unless agreed to otherwise in writing, paid for by the customer upfront.

7. Delivery

- 7.1 Unless agreed otherwise in writing delivery shall take place EXW (Ex Works) Naarden, the Netherlands, according to the latest version of the ICC Incoterms®.
- 7.2 BRAND VAN EGMOND will use reasonable endeavours to meet delivery estimates but in no circumstances shall it be liable to compensate the customer for non-delivery or late delivery.
- 7.3 BRAND VAN EGMOND reserves the right to deliver by instalments or in parts. Failure to meet a delivery date where delivery is by instalments shall not preclude BRAND VAN EGMOND's right to make further deliveries by instalments under the relevant contract.
- 7.4 The customer may request delivery by instalments for a maximum period of 12 months from the date of order.
- 7.5 The risk for the goods to be delivered shall pass to the customer from the moment that they are placed at the disposal of the customer at the premises of BRAND VAN EGMOND unless agreed to otherwise in writing. Any assistance by BRAND VAN EGMOND with the loading of the goods on any means of transportation shall be for the risk of the customer.

- 7.6 If delivery of the goods is refused by the customer, without prejudice to the provisions of article 9, the risk of the goods shall pass to the customer at once and BRAND VAN EGMOND can immediately claim payment. BRAND VAN EGMOND shall keep the goods at the customer's risks and expense until further notice.
- 7.7 If the customer continues to default after being summoned BRAND VAN EGMOND shall be entitled to dispose of the goods or to give them another destination. Any proceeds shall be credited to the customer with deduction of all expenses coming for his account, without prejudice to BRAND VAN EGMOND's right to full payment of the agreed price.

8. Inspection, defects and non-delivery, returns

- 8.1 The customer must inspect the products at the moment of delivery. BRAND VAN EGMOND shall not be liable for any defects in the products unless written notice with a statement of reasons is given to BRAND VAN EGMOND within seven (7) days of receipt. If complaints have not been made in the above mentioned manner and within the aforementioned period of seven (7) days, the delivery shall be considered unconditionally accepted.
- 8.2 The quantity of any consignment of products as recorded by BRAND VAN EGMOND upon despatch from BRAND VAN EGMOND's place of business shall be conclusive evidence of the quantity received by the customer on delivery, unless the customer can provide conclusive evidence to the contrary.
- 8.3 Customary deviations shall not be reasons for complaint. The photos on this web site, in our catalogue and brochures are provided to assist you in choosing the right product. These photos are meant to be samples only and are not intended to provide a perfect match to the actual product color. Colors and photo size may vary based upon your screen resolution and other computer settings outside of our control. The photo may differ from the actual product due to reproduction limitations of the photograph and limitations of viewing photos at different resolutions, hue, brightness, contrast, and other screen variations. Therefore, Brand van Egmond shall not be held responsible for any variation between the photos on this website/catalogue and the actual products you receive, including but not limited to: Color variation, grain variation, color change, and character variation
- 8.4 Any liability of BRAND VAN EGMOND for non-delivery or defective products shall to BRAND VAN EGMOND's discretion be limited to replacing, repairing or making up the products within a reasonable time.
- 8.5 No order can be cancelled or accepted without previous written agreement of BRAND VAN EGMOND.
- 8.6 Products may not be returned without BRAND VAN EGMOND's permission. If BRAND VAN EGMOND agrees to take the Products back, the customer shall obtain a return merchandise authorisation number (RMA number). Any products returned must be provided with the RMA number by the customer and be received by BRAND VAN EGMOND within seven (7) days of delivery and must be complete, undamaged and in original packaging. Products returned after seven (7) days as unwanted or incorrectly ordered will be accepted at the discretion of BRAND VAN EGMOND and will be subject to a restocking fee representing 30% of the invoice value of the products.
- 8.7 Certain products - such as products specially designed or manufactured for the customer - are excluded from any return. The customer is responsible for returning products to BRAND VAN EGMOND and for providing proof of delivery of such return.
- 8.8 Products will be returned at the customer's expense.

9. Retention of title

- 9.1 Ownership of the products shall not pass to the customer until BRAND VAN EGMOND has received in full (in cash or cleared funds) all sums due in respect of the products.
- 9.2 The customer shall not be entitled to alienate or encumber the products in any way as long as full payment has not been made to BRAND VAN EGMOND, except where and in so far as the normal conduct of business is concerned. The customer shall be obliged to pledge to BRAND VAN EGMOND any claims on third parties resulting from this, on pain of a fine to the amount of 50% of the invoice amount for the goods supplied, with a minimum of € 2.250,=.
- 9.3 If payment is not received in full by the due date, or the customer passes a resolution for winding up or a court shall make an order to that effect, or a receiver is appointed over any assets or the undertaking of the customer or an execution or distress is levied against the customer, BRAND VAN EGMOND shall be entitled, without previous notice, to retake possession of the products and for that purpose to enter upon any premises occupied or owned by the customer.

10. Performance and fitness for purpose

- 10.1 Unless any performance figures, tolerances or characteristics have been specifically and expressly warranted by a director of BRAND VAN EGMOND in writing, BRAND VAN EGMOND accepts no liability for any failure of the products to obtain such figures.
- 10.2 The responsibility for ensuring that products are sufficient and suitable for a particular purpose is the customer's, unless specifically stated in writing by a director of BRAND VAN EGMOND.
- 10.3 Any advice or recommendation given by an employee of BRAND VAN EGMOND, which is not confirmed in writing by a director of BRAND VAN EGMOND, is acted on entirely at the customer's risk and BRAND VAN EGMOND and its employees shall not be liable for any such advice or recommendation which is not so confirmed.

11. Guarantee

- 11.1 Each product has been manufactured and packaged to meet BRAND VAN EGMOND's high standards. Any defects which, under proper use, appear in the products within a period of twelve (12) months (unless otherwise stated by BRAND VAN EGMOND) and which are due to faulty materials, workmanship or design will be made good by BRAND VAN EGMOND either by repair, or at BRAND VAN EGMOND's option, replacement (which is BRAND VAN EGMOND's sole obligation and the customer's sole remedy).
- 11.2 BRAND VAN EGMOND's guarantee is accepted by the customer in substitution for all express or implied representations, conditions or warranties, statutory or otherwise, as to the satisfactory quality, fitness for purpose or performance of the products (or any materials used in connection therewith) or the standard of workmanship of any services provided, and all such representations, conditions and warranties are excluded.
- 11.3 BRAND VAN EGMOND shall not be liable for defective products if the defect arises because the customer alters or repairs such products without the written consent of BRAND VAN EGMOND or because the customer did not follow the manufacturers' instructions for storage, usage, installation, use or maintenance of the products.
- 11.4 Any products replaced or repaired under this paragraph will be guaranteed on these terms for any unexpired portion of the guarantee given on the original products.

12. Liability

- 12.1 These conditions of sales set out the entire liability of BRAND VAN EGMOND to the customer in respect of the products and shall be in lieu and to the exclusion of all other warranties, conditions, and other terms implied by statute or common law save for any implied terms which by law cannot be excluded.
- 12.2 Nothing in these conditions of sale excludes or limits the liability of BRAND VAN EGMOND for death or personal injury caused by BRAND VAN EGMOND's negligence or fraudulent misrepresentation.
- 12.3 BRAND VAN EGMOND's total liability in contract, tort (including negligence or breach of statutory duty), misrepresentation or otherwise shall be limited to repairing, replacing or at BRAND VAN EGMOND's option refunding monies already paid in respect of the products.
- 12.4 BRAND VAN EGMOND shall not be liable to the customer for any indirect or consequential loss or damage (whether for loss of profit, loss of business, loss of goodwill or otherwise) costs, expenses or other claims for consequential compensation whatsoever (whether caused by the negligence of BRAND VAN EGMOND, its employees, agents or subcontractors) which arise out or in connection with any contract.
- 12.5 BRAND VAN EGMOND shall not be liable for damage if the customer has not held BRAND VAN EGMOND liable for the damage by registered letter within a reasonable time after becoming aware of the cause of damage, but not later than thirty (30) days after becoming aware of the damage.
- 12.6 All stipulations concerning the exclusion or limitation of BRAND VAN EGMOND's liability for and concerning BRAND VAN EGMOND's indemnity against claims of third parties have also been made for the benefit of the persons who are employed by BRAND VAN EGMOND as well as third parties for whose actions or omissions BRAND VAN EGMOND can be liable.

13. Termination

- 13.1 If the customer is in default with timely payment or fulfilment of other obligations towards BRAND VAN EGMOND, BRAND VAN EGMOND shall remain entitled, without any notice of default, to consider the agreement rescinded, without prejudice to BRAND VAN EGMOND's right to full compensation of damage suffered and to be suffered and any further rights.
- 13.2 The power to rescind the agreement on the strength of article 13.1 shall also be due to BRAND VAN EGMOND if BRAND VAN EGMOND finds that the customer has filed an application for a provisional moratorium, is being declared bankrupt, goods of the customer are being attached before judgment or under an execution, or his debts are being liquidated.
- 13.3 The damage suffered and yet to be suffered as referred to in article 13.1. shall be at least 10% of the agreed price, without BRAND VAN EGMOND being obliged to prove that this damage has been or will be suffered.
- 13.4 In the event of rescission on the strength of article 13 any credit that BRAND VAN EGMOND has granted the customer shall be claimable immediately without further notice of default being required.

14. Intellectual property rights

- 14.1 The only BRAND VAN EGMOND trademarks and/or other rights of intellectual property that the customer may display to advertise and sell the products, shall be those trademarks and/or intellectual property rights under which the products are sold by BRAND VAN EGMOND to the customer hereunder, or such other trademarks expressly authorized by BRAND VAN EGMOND (hereinafter called "the said trademarks").
- 14.2 The customer shall comply with BRAND VAN EGMOND's instructions as to the manner and context in which the said trademarks and the statements to accompany them are displayed.
- 14.3 No trademarks of the products shall be undertaken by the customer or any person on the customer's behalf without BRAND VAN EGMOND's prior written consent nor will the customer alter, obliterate, add to, or otherwise interfere with the said trademarks and/or other intellectual property rights.

15. Export

- 15.1 The customer is responsible at its own expense for obtaining any licence and complying with any export or import regulations in force within the country for which the products are destined.
- 15.2 BRAND VAN EGMOND reserves the right not to supply certain customers or countries and to seek from the customer full details of the end use and final destination of the products.

16. Force majeure

- 16.1 BRAND VAN EGMOND shall not be liable to the customer in any manner or be deemed to be in breach of these conditions of sale because of any delay in performing or any failure to perform any of BRAND VAN EGMOND's obligations under these conditions of sale if the delay or failure was due to any cause beyond BRAND VAN EGMOND's reasonable control (which shall include, but not be limited to government actions, war, fire, explosion, flood, import or export regulations or embargoes, labour disputes or inability to obtain or a delay in obtaining supplies of products or labour, lack and/or interruptions in the means of transport, production equipment or energy supplies).
- 16.2 BRAND VAN EGMOND may, at its option, delay the performance of, or cancel the whole or any part of a contract.

17. General

- 17.1 Any provision of these conditions of sale which is held by any competent authority to be invalid, void, unenforceable or unreasonable (in whole or in part) shall to the extent of such invalidity, voidness, voidability, unenforceability or unreasonableness be deemed severable and the other provisions of these Conditions of Sale and the remainder of such provision shall not be affected.
- 17.2 Failure by BRAND VAN EGMOND to enforce or partially enforce any provision of these conditions of sale will not be constrained as a waiver of any rights under these conditions of sale.

18. Legal construction

- 18.1 All disputes, suits, actions or other legal proceedings arising out of or related to these conditions of sale shall be governed by and interpreted in accordance with the laws of the Netherlands and the customer submits to the jurisdiction of the courts of the Netherlands, but BRAND VAN EGMOND may enforce such contract in any court of competent jurisdiction.
- 18.2 The United Nations Convention on contracts for the International Sale of Goods (1980) is not applicable (CISG).



All rights reserved, copyright© Brand van Egmond B.V. © 2023.

For all models, texts, layout and images BrandvanEgmond, Interiors designed by studiodutchdelight.com. Specifications are subject to change without prior notice. Brand van Egmond manufactures exclusive lighting sculptures on a small scale. Because their products are handmade, they can differ from one another. Each product has its own identity and therefore is unique. Each item is labelled with its own number and certificate. Brand van Egmond reserves the right to change their models from time to time without prior notice. The designs, texts, layout or pictures included in this brochure are subject to errors, technical changes and protected by copyright and/or industrial design rights. No part there of may be made public, reproduced or amended in any form or in any manner whatsoever, for commercial purposes by third parties, including dealers, retailers, internet shops and others, without the prior and express written permission of the designer William Brand).

Colophon

BRAND VAN EGMOND

William Brand

Photography by

SmartStudio / www.smartstudio.pl

Rendering images and Interior design

Studiodutchdelight.com

New Collections 2023



BRAND VAN EGMOND B.V. Nikkelstraat 41, 1411 AH Naarden, The Netherlands

T. +31 (0)35 692 12 59 info@brandvanegmond.com www.brandvanegmond.com

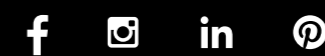

New Collections 2023